

MAGNETIC WORKHOLDING

Grinding | Pallet | Milling | EDM | Turning | Lifting | Testing

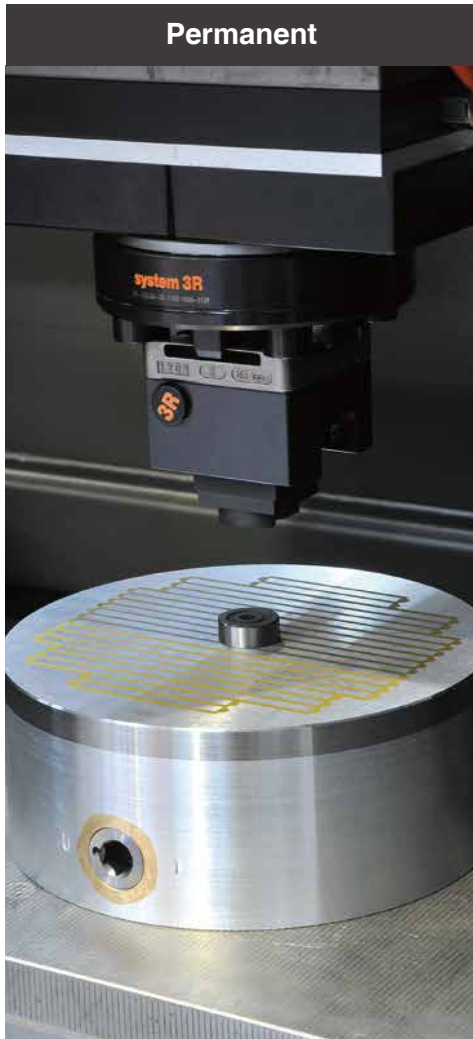

BRISC®

Magnetic Workholding Applications

Table of contents



Grinding	
EMA	01
EMT	02
EPA	03
EPT	04
EPD	05
EME	07
EPB	08
EMM	09
EPM	10
EPS	11
PMF	12
PMT	13
EMK	14
EPZ	15
Pallet	
PPN / PPA	16
PPC / PPM	17
Milling	
XP70	18
PSP	19
POLE EXTENSION	20
PRP	21
PMM	22
PZP	23
PCC	24
EPK	26
Testing	
CFT	26
EDM	
PFD	27
MBF	28
NF	29
PMB	30
PMG	31
Turning / Grinding	
PMY	32
NY	33
EPY	34
NR	35
EMW	36
EPW	37
EMY	38
EPQ	39
PR	40
Lifting magnets	
SAFER	41
SAFER-T	42
SAFER-R	43
BLM / PRA	44
Control unit	
CUA / CUD / CUT	45
CGA / CGD / JB	46
CU / CG / RMC	47
CEB / CUK	48

Driven by magnetics

Soph offers the most comprehensive package of magnetic solutions for workholding, mold and die clamping and material handling. Starting the business in 1998, until now Soph owns the trademarks and business of Brisc, Magbo and Helmholtz which is for workholding, mold and die clamping and material handling respectively. Based in Hamburg Germany, after years of development, Soph now has branches in USA and China.

By installing one of the largest finished product inventories and training highly skilled service and sales engineers, Soph has created a substantial reference base in Europe, North America and Far east in a relatively short time. Our ability to provide immediate technical answers, immediate service, custom design, OEM specific products and product lines keeps us ahead of the curve.

With creative problem solving and application specific solutions, Soph is considered to be one of the finest sources for magnetic solutions available. We are dedicated to provide the best product with the best performance to match each application. By using customer input we are able to provide tailor made solutions using standardized products to create unmatched value in substantially shorter market cycles.

Products	Permanent	Electro	Electro-permanent
Grinding	PMF / PMT / NR PMY / NY / PMM PFD / MBF / NF PMB / PMG	EMA / EME / EMV EMM / EMK	EPA / EPB / EPD EPM / EPN / EPS EPW / EPZ
Pallet	PPA / PPC / PPM		PPN
Milling	PMM / NF / PMB PMG	EMT	EPK / PSP / PRP PZP / PCC / XP70 EPT
EDM	PFD / MBF / NF PMB / PMG / PMF PMT / PMY		
Turning	PMY / NY / NR NF	EMW / EMY	EPY / EPW / EPQ PR
Lifting	SAFER / SAFER-T SAFER-R / BLM PRA		
Testing	CFT	CFT	CFT



GRINDING



PALLET



MILLING



EDM



TURNING



LIFTING

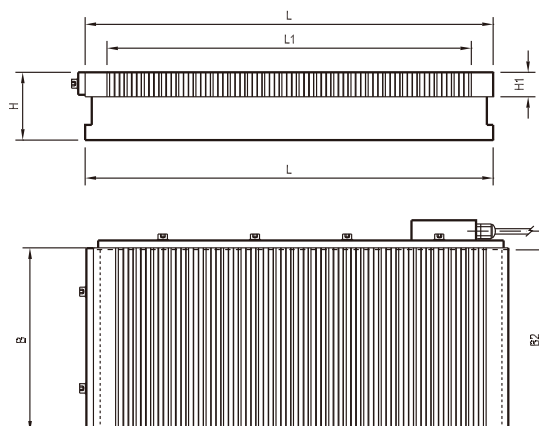

• Finepitch electromagnetic chuck

Use:

For versatile clamping on a broad range of workpiece sizes

Features:

- Pole pitch 5+0.5+5+0.5+5+3 mm
- Highest uniform clamping force up to 140 N/cm²
- Less than 5°C chuck temperature rise after 1 hour working
- Mono-block housing for maximum stability
- Low current with minimum power consumption
- Low profile for more wheel head clearance
- Versatile clamping, excellent holding on a broad range of workpiece size



Model	Width(B)	Length(L)	Base Width(B2)	Height(H)	L1	H1	Voltage	Current	Net Weight
EMA-3060	300 (11.82)	600 (23.62)	294 (11.57)	80 (3.15)	554 (21.81)	27 (1.06)	DC 110 V	0.78 A	107 kg / 236 lb
EMA-3080	300 (11.82)	800 (31.50)	294 (11.57)	80 (3.15)	744 (29.29)	27 (1.06)	DC 110 V	1 A	143 kg / 315 lb
EMA-30100	300 (11.82)	1000 (39.37)	294 (11.57)	80 (3.15)	934 (36.77)	27 (1.06)	DC 110 V	1.2 A	179 kg / 394 lb
EMA-30120	300 (11.82)	1200 (47.24)	294 (11.57)	80 (3.15)	1124 (44.25)	27 (1.06)	DC 110 V	1.6 A	215 kg / 473 lb
EMA-30150	300 (11.82)	1500 (59.06)	294 (11.57)	80 (3.15)	1428 (56.22)	27 (1.06)	DC 110 V	2.1 A	268 kg / 591 lb
EMA-4060	400 (15.75)	600 (23.62)	394 (15.51)	80 (3.15)	554 (21.81)	27 (1.06)	DC 110 V	1.2 A	143 kg / 315 lb
EMA-4080	400 (15.75)	800 (31.50)	394 (15.51)	80 (3.15)	744 (29.29)	27 (1.06)	DC 110 V	1.4 A	191 kg / 420 lb
EMA-40100	400 (15.75)	1000 (39.37)	394 (15.51)	80 (3.15)	934 (36.77)	27 (1.06)	DC 110 V	1.9 A	239 kg / 525 lb
EMA-40120	400 (15.75)	1200 (47.24)	394 (15.51)	80 (3.15)	1124 (44.25)	27 (1.06)	DC 110 V	2.2 A	286 kg / 630 lb
EMA-40150	400 (15.75)	1500 (59.06)	394 (15.51)	80 (3.15)	1428 (56.22)	27 (1.06)	DC 110 V	2.5 A	358 kg / 788 lb
EMA-40200	400 (15.75)	1000 (39.37)*2	394 (15.51)	80 (3.15)	934 (36.22)*2	27 (1.06)	DC 110 V	1.9 A*2	477 kg / 1050 lb
EMA-5060	500 (19.69)	600 (23.62)	494 (19.45)	80 (3.15)	554 (21.81)	27 (1.06)	DC 110 V	1.2 A	179 kg / 394 lb
EMA-5080	500 (19.69)	800 (31.50)	494 (19.45)	80 (3.15)	744 (29.29)	27 (1.06)	DC 110 V	1.5 A	239 kg / 525 lb
EMA-50100	500 (19.69)	1000 (39.37)	494 (19.45)	80 (3.15)	934 (36.77)	27 (1.06)	DC 110 V	1.7 A	298 kg / 656 lb
EMA-50120	500 (19.69)	1200 (47.24)	494 (19.45)	80 (3.15)	1124 (44.25)	27 (1.06)	DC 110 V	1.9 A	358 kg / 788 lb
EMA-50150	500 (19.69)	1500 (59.06)	494 (19.45)	80 (3.15)	1428 (56.22)	27 (1.06)	DC 110 V	2.6 A	447 kg / 984 lb
EMA-50200	500 (19.69)	1000 (39.37)*2	494 (19.45)	80 (3.15)	934 (36.22)*2	27 (1.06)	DC 110 V	1.7 A*2	597 kg / 1313 lb
EMA-6080	600 (23.62)	800 (31.50)	594 (23.39)	85 (3.35)	744 (29.29)	27 (1.06)	DC 110 V	1.5 A	304 kg / 669 lb
EMA-60100	600 (23.62)	1000 (39.37)	594 (23.39)	85 (3.35)	934 (36.77)	27 (1.06)	DC 110 V	2.2 A	336 kg / 738 lb
EMA-60120	600 (23.62)	1200 (47.24)	594 (23.39)	85 (3.35)	1124 (44.25)	27 (1.06)	DC 110 V	2.4 A	456 kg / 1004 lb
EMA-60150	600 (23.62)	1500 (59.06)	594 (23.39)	85 (3.35)	1428 (56.22)	27 (1.06)	DC 110 V	2.4 A	570 kg / 1255 lb
EMA-60200	600 (23.62)	1000 (39.37)*2	594 (23.39)	85 (3.35)	934 (36.22)*2	27 (1.06)	DC 110 V	2.2 A*2	761 kg / 1673 lb
EMA-70150	700 (27.56)	1500 (59.06)	694 (27.32)	85 (3.35)	1428 (56.22)	27 (1.06)	DC 110 V	2.4 A	666 kg / 1464 lb
EMA-80200	800 (31.50)	1000 (39.37)*2	794 (31.25)	85 (3.35)	934 (36.22)*2	27 (1.06)	DC 110 V	2.9 A*2	1014 kg / 2231 lb
EMA-100150	1000 (39.37)	1500 (59.06)	994 (39.13)	85 (3.35)	1428 (56.22)	27 (1.06)	DC 110 V	5 A*2	951 kg / 2092 lb
EMA-100200	1000 (39.37)	1000 (39.37)*2	994 (39.13)	85 (3.35)	934 (36.22)*2	27 (1.06)	DC 110 V	3.3 A*2	1268 kg / 2789 lb
EMA-120200	1200 (47.24)	1000 (39.37)*2	1194 (47.01)	85 (3.35)	934 (36.22)*2	27 (1.06)	DC 110 V	4 A*2	1521 kg / 3347 lb
EMA-120300	1200 (47.24)	1000 (39.37)*3	1194 (47.01)	85 (3.35)	934 (36.22)*3	27 (1.06)	DC 110 V	4 A*3	2282 kg / 5020 lb
EMA-150300	1500 (59.06)	1000 (39.37)*3	1494 (52.82)	85 (3.35)	934 (36.22)*3	27 (1.06)	DC 110 V	6.5 A*3	2852 kg / 6275 lb
EMA-150500	1500 (59.06)	1000 (39.37)*5	1492 (52.82)	85 (3.35)	934 (36.22)*5	27 (1.06)	DC 110 V	6.5 A*5	4754 kg / 10459 lb

Unit: mm(in)

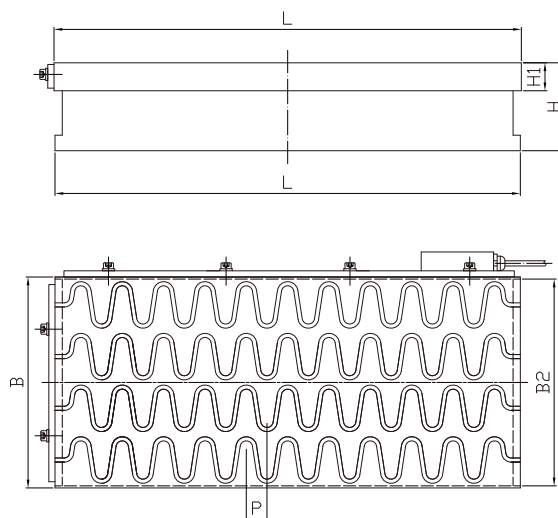

Grinding

• Waved pole pitch electromagnetic chuck

Use:

For versatile clamping on a broad range of workpiece sizes

Features:

- Pole pitch 11 / 14 / 20 / 25 / 36 mm
- Highest uniform clamping force up to 160 N/cm²
- Less than 5°C chuck temperature rise after 1 hour working
- Mono block housing for maximum stability
- Low current with minimum power consumption
- Low profile for more wheel head clearance
- Full surface magnetic power

Model	Width(B)	Length(L)	Base Width(B2)	Height(H)	H1	Voltage	Current	Net Weight
EMT 3060	302 (11.89)	600 (23.62)	300 (11.81)	85 (3.35)	27 (1.06)	DC 110 V	1.1A	114 kg / 251 lb
EMT 3080	302 (11.89)	800 (31.50)	300 (11.81)	85 (3.35)	27 (1.06)	DC 110 V	1.2A	152 kg / 334 lb
EMT 30100	302 (11.89)	1000 (39.37)	300 (11.81)	85 (3.35)	27 (1.06)	DC 110 V	1.4A	190 kg / 418 lb
EMT 30120	302 (11.89)	1200 (47.24)	300 (11.81)	85 (3.35)	27 (1.06)	DC 110 V	1.6A	228 kg / 502 lb
EMT 30150	302 (11.89)	1500 (59.06)	300 (11.81)	85 (3.35)	27 (1.06)	DC 110 V	1.8A	285 kg / 628 lb
EMT 4060	402 (15.83)	600 (23.62)	400 (15.75)	85 (3.35)	27 (1.06)	DC 110 V	2.0A	152 kg / 335 lb
EMT 4080	402 (15.83)	800 (31.50)	400 (15.75)	85 (3.35)	27 (1.06)	DC 110 V	2.7A	203 kg / 446 lb
EMT 40100	402 (15.83)	1000 (39.37)	400 (15.75)	85 (3.35)	27 (1.06)	DC 110 V	2.8A	254 kg / 558 lb
EMT 40120	402 (15.83)	1200 (47.24)	400 (15.75)	85 (3.35)	27 (1.06)	DC 110 V	2.9A	304 kg / 669 lb
EMT 40150	402 (15.83)	1500 (59.06)	400 (15.75)	85 (3.35)	27 (1.06)	DC 110 V	3.0A	380 kg / 837 lb
EMT 40200	402 (15.83)	1000 (39.37)*2	400 (15.75)	85 (3.35)	27 (1.06)	DC 110 V	2.8A*2	507 kg / 1116 lb
EMT 5060	502 (19.76)	600 (23.62)	500 (19.69)	85 (3.35)	27 (1.06)	DC 110 V	2.5A	190 kg / 418 lb
EMT 5080	502 (19.76)	800 (31.50)	500 (19.69)	85 (3.35)	27 (1.06)	DC 110 V	3.0A	254 kg / 558 lb
EMT 50100	502 (19.76)	1000 (39.37)	500 (19.69)	85 (3.35)	27 (1.06)	DC 110 V	3.3A	317 kg / 697 lb
EMT 50120	502 (19.76)	1200 (47.24)	500 (19.69)	85 (3.35)	27 (1.06)	DC 110 V	3.4A	380 kg / 837 lb
EMT 50150	502 (19.76)	1500 (59.06)	500 (19.69)	85 (3.35)	27 (1.06)	DC 110 V	4.0A	475 kg / 1046 lb
EMT 50200	502 (19.76)	1000 (39.37)*2	500 (19.69)	85 (3.35)	27 (1.06)	DC 110 V	3.3A*2	634 kg / 1395 lb
EMT 6080	602 (23.70)	800 (31.50)	600 (23.62)	85 (3.35)	27 (1.06)	DC 110 V	3.5A	304 kg / 669 lb
EMT 60100	602 (23.70)	1000 (39.37)	600 (23.62)	85 (3.35)	27 (1.06)	DC 110 V	3.8A	336 kg / 738 lb
EMT 60120	602 (23.70)	1200 (47.24)	600 (23.62)	85 (3.35)	27 (1.06)	DC 110 V	4.0A	456 kg / 1004 lb
EMT 60150	602 (23.70)	1500 (59.06)	600 (23.62)	85 (3.35)	27 (1.06)	DC 110 V	4.5A	570 kg / 1255 lb
EMT 60200	602 (23.70)	1000 (39.37)*2	600 (23.62)	85 (3.35)	27 (1.06)	DC 110 V	3.8A*2	761 kg / 1673 lb
EMT 70150	702 (27.64)	1500 (59.06)	700 (27.56)	85 (3.35)	27 (1.06)	DC 110 V		666 kg / 1464 lb
EMT 80200	802 (31.57)	1000 (39.37)*2	800 (31.50)	85 (3.35)	27 (1.06)	DC 110 V		1014 kg / 2231 lb
EMT 100150	1002 (39.45)	1500 (59.06)	1000 (39.37)	85 (3.35)	27 (1.06)	DC 110 V		951 kg / 2092 lb
EMT 100200	1002 (39.45)	1000 (39.37)*2	1000 (39.37)	85 (3.35)	27 (1.06)	DC 110 V		1268 kg / 2789 lb
EMT 120200	1202 (39.45)	1000 (39.37)*2	1200 (47.24)	85 (3.35)	27 (1.06)	DC 110 V		1521 kg / 3347 lb
EMT 120300	1202 (39.45)	1000 (39.37)*3	1200 (47.24)	85 (3.35)	27 (1.06)	DC 110 V		2282 kg / 5020 lb
EMT 150300	1502 (59.13)	1000 (39.37)*3	1500 (59.06)	85 (3.35)	27 (1.06)	DC 110 V		2852 kg / 6275 lb
EMT 150500	1502 (59.13)	1000 (39.37)*5	1500 (59.06)	85 (3.35)	27 (1.06)	DC 110 V		4754 kg / 10459 lb

Unit: mm(in)

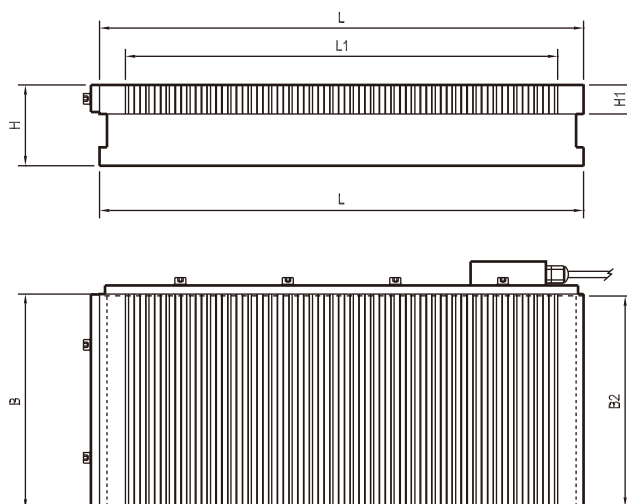
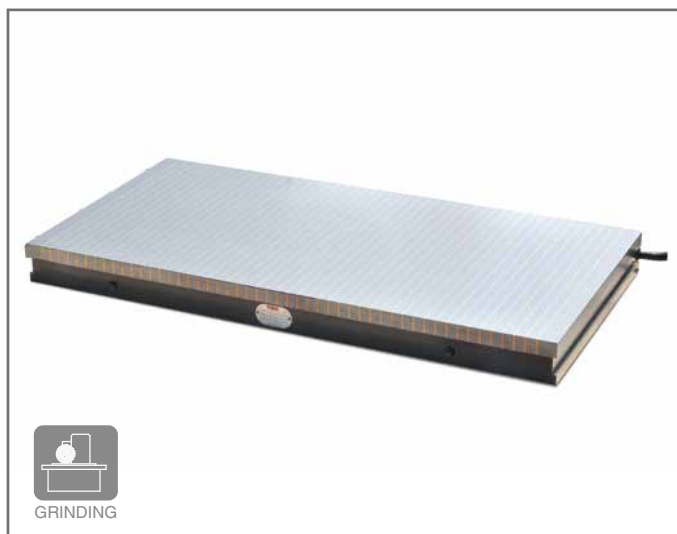

• Finepitch electro-permanent magnetic chuck

Use:

For versatile clamping on a broad range of workpiece sizes

Features:

- Pole pitch 5+0.5+5+0.5+5+3 mm
- Highest uniform clamping force up to 140 N/cm²
- Electro-permanent magnetic technology with no deformation owing to the rise of temperature
- Can eliminate residual magnetism from the workpiece
- Coolant and water proof structure
- Mono-block housing for maximum stability



Model	Width(B)	Length(L)	Base Width(B2)	Height(H)	L1	H1	Net Weight	Controller (400V)
EPA-3060	304 (11.97)	600 (23.62)	300 (11.81)	85 (3.35)	554 (21.81)	27 (1.06)	114 kg / 251 lb	CGA
EPA-3080	304 (11.97)	800 (31.50)	300 (11.81)	85 (3.35)	744 (29.29)	27 (1.06)	152 kg / 334 lb	CGA
EPA-30100	304 (11.97)	1000 (39.40)	300 (11.81)	85 (3.35)	934 (36.77)	27 (1.06)	190 kg / 415 lb	CGA
EPA-30120	304 (11.97)	1200 (47.28)	300 (11.81)	85 (3.35)	1124 (44.25)	27 (1.06)	228 kg / 502 lb	CGA
EPA-30150	304 (11.97)	1500 (59.10)	300 (11.81)	85 (3.35)	1428 (56.22)	27 (1.06)	285 kg / 628 lb	CGA
EPA-4060	404 (15.91)	600 (23.62)	400 (15.75)	85 (3.35)	554 (21.81)	27 (1.06)	152 kg / 335 lb	CGA
EPA-4080	404 (15.91)	800 (31.50)	400 (15.75)	85 (3.35)	744 (29.29)	27 (1.06)	203 kg / 446 lb	CGA
EPA-40100	404 (15.91)	1000 (39.40)	400 (15.75)	85 (3.35)	934 (36.77)	27 (1.06)	254 kg / 558 lb	CGA
EPA-40120	404 (15.91)	1200 (47.28)	400 (15.75)	85 (3.35)	1124 (44.25)	27 (1.06)	304 kg / 669 lb	CGA
EPA-40150	404 (15.91)	1500 (59.10)	400 (15.75)	85 (3.35)	1428 (56.22)	27 (1.06)	380 kg / 837 lb	CGA
EPA-40200	404 (15.91)	1000*2 (39.40*2)	400 (15.75)	85 (3.35)	934 (36.77)	27 (1.06)	507 kg / 1116 lb	CGA
EPA-5060	504 (19.84)	600 (23.62)	500 (19.70)	85 (3.35)	554 (21.81)	27 (1.06)	190 kg / 418 lb	CGA
EPA-5080	504 (19.84)	800 (31.50)	500 (19.70)	85 (3.35)	744 (29.29)	27 (1.06)	254 kg / 558 lb	CGA
EPA-50100	504 (19.84)	1000 (39.40)	500 (19.70)	85 (3.35)	934 (36.77)	27 (1.06)	317 kg / 697 lb	CGA
EPA-50120	504 (19.84)	1200 (47.28)	500 (19.70)	85 (3.35)	1124 (44.25)	27 (1.06)	380 kg / 837 lb	CGA
EPA-50150	504 (19.84)	1500 (59.10)	500 (19.70)	85 (3.35)	1428 (56.22)	27 (1.06)	475 kg / 1046 lb	CGA
EPA-50200	504 (19.84)	1000 (39.37)*2	500 (19.70)	85 (3.35)	934 (36.77)	27 (1.06)	634 kg / 1395 lb	CGD
EPA-6080	604 (23.78)	800 (31.50)	600 (23.64)	85 (3.35)	744 (30.47)	27 (1.06)	304 kg / 669 lb	CGA
EPA-60100	604 (23.78)	1000 (39.40)	600 (23.64)	85 (3.35)	934 (36.77)	27 (1.06)	336 kg / 738 lb	CGA
EPA-60120	604 (23.78)	1200 (47.28)	600 (23.64)	85 (3.35)	1124 (44.25)	27 (1.06)	456 kg / 1004 lb	CGA
EPA-60150	604 (23.78)	1500 (59.10)	600 (23.64)	85 (3.35)	1428 (56.22)	27 (1.06)	570 kg / 1255 lb	CGA
EPA-60200	604 (23.78)	1000 (39.37)*2	600 (23.64)	85 (3.35)	934 (36.77)	27 (1.06)	761 kg / 1673 lb	CGD
EPA-60220	604 (23.78)	1100 (43.30)*2	600 (23.64)	85 (3.35)	1048 (41.26)	27 (1.06)	837 kg / 1841 lb	CGD
EPA-60250	604 (23.78)	1250 (49.21)*2	600 (23.64)	85 (3.35)	1184 (46.61)	27 (1.06)	950 kg / 2090 lb	CGD
EPA-70150	704 (27.72)	1500 (59.10)	700 (27.58)	85 (3.35)	1428 (56.22)	27 (1.06)	666 kg / 1464 lb	CGA
EPA-75150	750 (29.53)	1500 (59.10)	744 (29.29)	85 (3.35)	1428 (56.22)	27 (1.06)	713 kg / 1569 lb	CGA

Unit: mm(in)

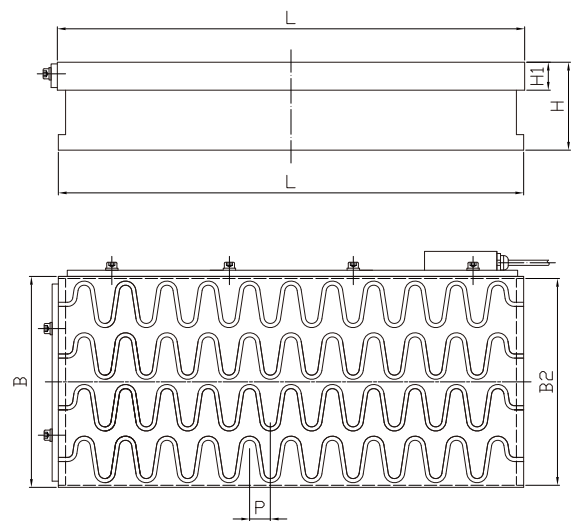

Grinding

● Finepitch electro-permanent magnetic chuck

Use:

For versatile clamping on a broad range of workpiece sizes

Features:

- Pole pitch 11 / 14 / 20 / 25 / 36 mm
- Highest uniform clamping force up to 160 N/cm²
- Electro-permanent magnetic technology with no deformation owing to the rise of temperature
- Can eliminate residual magnetism from the workpiece
- Coolant and water proof structure
- Mono-block housing for maximum stability

Model	Width(B)	Length(L)	Base Width(B2)	Height(H)	H1	Net Weight	Controller (400V)
EPT-3060	302 (11.89)	600 (23.62)	300 (11.81)	85 (3.35)	27 (1.06)	114 kg / 251 lb	CGA
EPT-3080	302 (11.89)	800 (31.52)	300 (11.81)	85 (3.35)	27 (1.06)	152 kg / 334 lb	CGA
EPT-30100	302 (11.89)	1000 (39.40)	300 (11.81)	85 (3.35)	27 (1.06)	190 kg / 415 lb	CGA
EPT-30120	302 (11.89)	1200 (47.28)	300 (11.81)	85 (3.35)	27 (1.06)	228 kg / 502 lb	CGA
EPT-30150	302 (11.89)	1500 (59.10)	300 (11.81)	85 (3.35)	27 (1.06)	285 kg / 628 lb	CGA
EPT-4060	402 (15.83)	600 (23.62)	400 (15.75)	85 (3.35)	27 (1.06)	152 kg / 335 lb	CGA
EPT-4080	402 (15.83)	800 (31.52)	400 (15.75)	85 (3.35)	27 (1.06)	203 kg / 446 lb	CGA
EPT-40100	402 (15.83)	1000 (39.40)	400 (15.75)	85 (3.35)	27 (1.06)	254 kg / 558 lb	CGA
EPT-40120	402 (15.83)	1200 (47.28)	400 (15.75)	85 (3.35)	27 (1.06)	304 kg / 669 lb	CGA
EPT-40150	402 (15.83)	1500 (59.10)	400 (15.75)	85 (3.35)	27 (1.06)	380 kg / 837 lb	CGA
EPT-40200	402 (15.83)	1000 (39.37)*2	400 (15.75)	85 (3.35)	27 (1.06)	507 kg / 1116 lb	CGA
EPT-5060	502 (19.76)	600 (23.62)	500 (19.70)	85 (3.35)	27 (1.06)	190 kg / 418 lb	CGA
EPT-5080	502 (19.76)	800 (31.52)	500 (19.70)	85 (3.35)	27 (1.06)	254 kg / 558 lb	CGA
EPT-50100	502 (19.76)	1000 (39.40)	500 (19.70)	85 (3.35)	27 (1.06)	317 kg / 697 lb	CGA
EPT-50120	502 (19.76)	1200 (47.28)	500 (19.70)	85 (3.35)	27 (1.06)	380 kg / 837 lb	CGA
EPT-50150	502 (19.76)	1500 (59.10)	500 (19.70)	85 (3.35)	27 (1.06)	475 kg / 1046 lb	CGA
EPT-50200	502 (19.76)	1000 (39.37)*2	500 (19.70)	85 (3.35)	27 (1.06)	634 kg / 1395 lb	CGD
EPT-6080	602 (23.70)	800 (31.52)	500 (19.70)	85 (3.35)	27 (1.06)	304 kg / 669 lb	CGA
EPT-60100	602 (23.70)	1000 (39.40)	600 (23.64)	85 (3.35)	27 (1.06)	336 kg / 738 lb	CGA
EPT-60120	602 (23.70)	1200 (47.28)	600 (23.64)	85 (3.35)	27 (1.06)	456 kg / 1004 lb	CGA
EPT-60150	602 (23.70)	1500 (59.10)	600 (23.64)	85 (3.35)	27 (1.06)	570 kg / 1255 lb	CGA
EPT-60200	602 (23.70)	1000 (39.37)*2	600 (23.64)	85 (3.35)	27 (1.06)	761 kg / 1673 lb	CGD
EPT-60220	602 (23.70)	1100 (43.30)*2	600 (23.64)	85 (3.35)	27 (1.06)	837 kg / 1841 lb	CGD
EPT-60250	602 (23.70)	1250 (49.21)*2	600 (23.64)	85 (3.35)	27 (1.06)	950 kg / 2090 lb	CGD
EPT-70150	702 (27.64)	1500 (59.10)	700 (27.58)	85 (3.35)	27 (1.06)	666 kg / 1464 lb	CGA

Unit: mm(in)

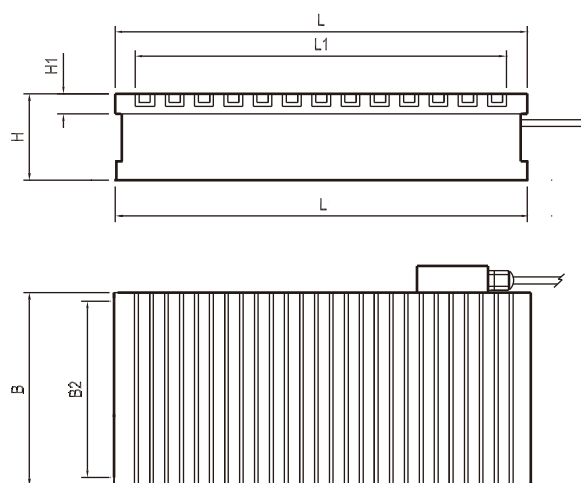
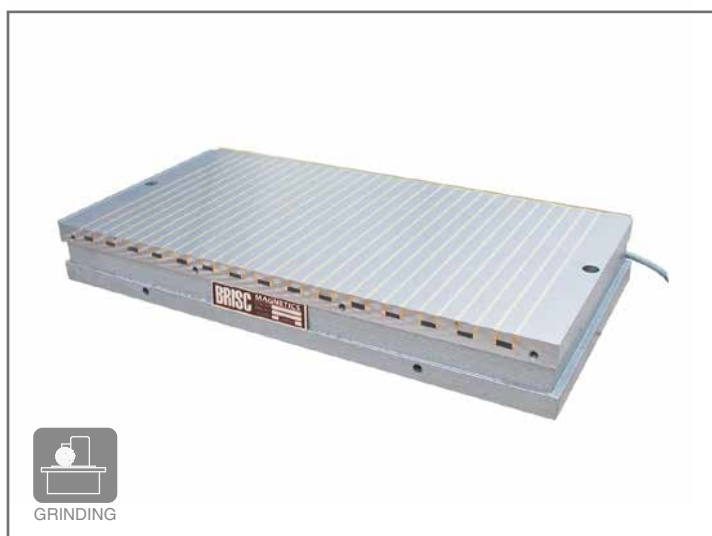

● **Standard pitch electro-permanent magnetic chuck**

Use:

For universal clamping with higher magnetic force

Features:

- Pole pitch 3+16 mm
- Highest clamping force up to 140 N/cm²
- Electro-permanent technology with no deformation owing to the rise of the temperature
- Can eliminate the residual magnetism from the workpiece
- Solid top plate with high precision
- Minimum mechanical deformation with solid one-piece housing

Model	Width (B)	Length (L)	B2	Height	L1	H1	Controller (400V)	Net Weight
EPD-1530	150 (5.91)	300 (11.81)	144 (5.67)	80 (3.15)	237 (9.33)	27 (1.06)	CGA	25 kg / 55 lb
EPD-1535	150 (5.91)	350 (13.78)	144 (5.67)	80 (3.15)	291 (11.46)	27 (1.06)	CGA	29 kg / 64 lb
EPD-1540	150 (5.91)	400 (15.75)	144 (5.67)	80 (3.15)	345 (13.58)	27 (1.06)	CGA	34 kg / 75 lb
EPD-1545	150 (5.91)	450 (17.72)	144 (5.67)	80 (3.15)	381 (15.00)	27 (1.06)	CGA	38 kg / 84 lb
EPD-2040	204 (8.03)	400 (15.75)	200 (7.87)	85 (3.35)	345 (13.58)	27 (1.06)	CGA	51 kg / 112 lb
EPD-2045	204 (8.03)	450 (15.75)	200 (7.87)	85 (3.35)	381 (15.00)	27 (1.06)	CGA	57 kg / 126 lb
EPD-2050	204 (8.03)	500 (19.69)	200 (7.87)	85 (3.35)	435 (17.13)	27 (1.06)	CGA	63 kg / 139 lb
EPD-2550	250 (9.84)	500 (19.69)	194 (7.64)	85 (3.35)	435 (17.13)	27 (1.06)	CGA	70 kg / 153 lb
EPD-3060	304 (11.97)	600 (23.62)	300 (11.81)	85 (3.35)	543 (21.38)	27 (1.06)	CGA	114 kg / 251 lb
EPD-4080	404 (15.91)	800 (31.50)	400 (15.75)	85 (3.35)	741 (29.17)	27 (1.06)	CGA	203 kg / 446 lb
EPD-40100	404 (15.91)	1000 (39.37)	400 (15.75)	85 (3.35)	939 (36.97)	27 (1.06)	CGA	254 kg / 558 lb
EPD-40150	404 (15.91)	1500 (59.05)	400 (15.75)	85 (3.35)	1443 (56.81)	27 (1.06)	CGA	380 kg / 837 lb
EPD-5080	504 (19.84)	800 (31.50)	500 (19.69)	85 (3.35)	741 (29.17)	27 (1.06)	CGA	254 kg / 558 lb
EPD-50100	504 (19.84)	1000 (39.37)	500 (19.69)	85 (3.35)	939 (36.97)	27 (1.06)	CGA	317 kg / 697 lb
EPD-50150	504 (19.84)	1500 (59.05)	500 (19.69)	85 (3.35)	1443 (56.81)	27 (1.06)	CGA	475 kg / 1046 lb
EPD-50200	504 (19.84)	1000 (39.37)*2	500 (19.69)	85 (3.35)	939 (36.97)*2	27 (1.06)	CGD	634 kg / 1395 lb
EPD-6080	604 (23.78)	800 (31.50)	600 (23.62)	85 (3.35)	741 (29.17)	27 (1.06)	CGA	304 kg / 669 lb
EPD-60100	604 (23.78)	1000 (39.37)	600 (23.62)	85 (3.35)	939 (36.97)	27 (1.06)	CGA	380 kg / 837 lb
EPD-60150	604 (23.78)	1500 (59.05)	600 (23.62)	85 (3.35)	1443 (56.81)	27 (1.06)	CGA	570 kg / 1255 lb
EPD-60200	604 (23.78)	1000 (39.37)*2	600 (23.62)	85 (3.35)	939 (36.97)*2	27 (1.06)	CGD	761 kg / 1673 lb

Unit: mm(in)

EPD-3060-RL

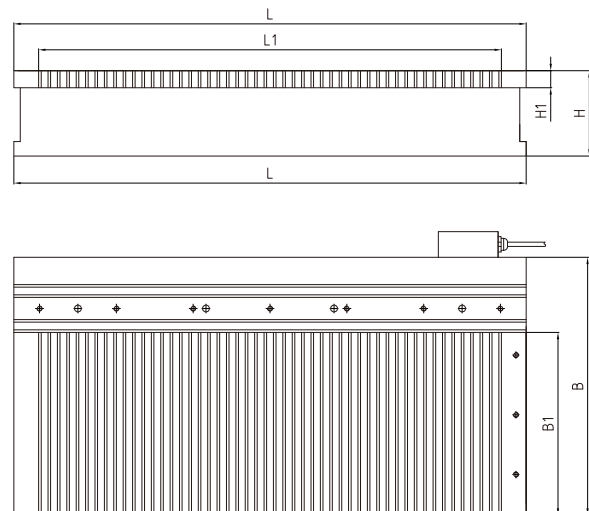

● Standard pitch electro-permanent magnetic chuck

Use:

For sliding block clamping with extra clamping force on the back step

Features:

- Pole pitch 3+8 mm
- Highest clamping force up to 140 N/cm²
- Electro-permanent technology with no deformation owing to the rise of the temperature
- Can eliminate the residual magnetism from the workpiece
- Solid top plate with high precision
- Minimum mechanical deformation with solid one-piece housing

Model	Width(B)	Length(L)	Height(H)	B1	L1	H1	Controller (220/400V)	Net Weight
EPD-3060-RL	302 (11.88)	600 (23.62)	100 (3.94)	241 (9.49)	542 (2.13)	20 (0.78)	CGA	150 kg / 330 lb

Unit: mm(in)

EPD-08100

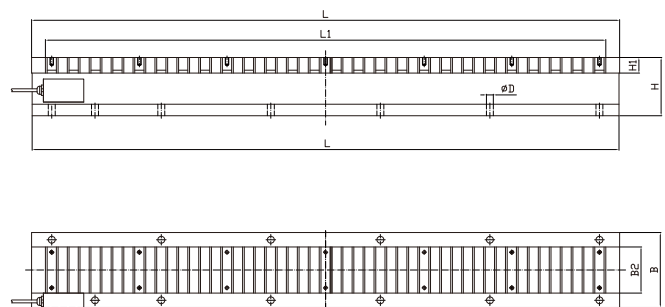
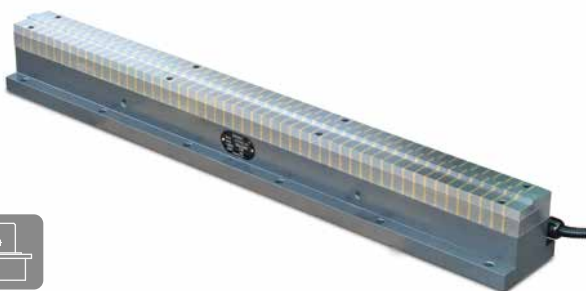

● Standard pitch electro-permanent magnetic chuck

Use:

For linear guide rail clamping

Features:

- Pole pitch 3+16 mm
- Highest clamping force up to 140 N/cm²
- Electro-permanent technology with no deformation owing to the rise of the temperature
- Can eliminate the residual magnetism from the workpiece
- Solid top plate with high precision
- Minimum mechanical deformation with solid one-piece housing

Model	Width(B)	Length(L)	Height(H)	B2	L1	H1	Controller (220/400V)	Net Weight
EPD 08100	130 (5.12)	1020 (40.16)	101 (3.98)	80 (3.15)	972 (38.27)	27 (1.06)	CGA	70 kg / 154 lb

Unit: mm(in)

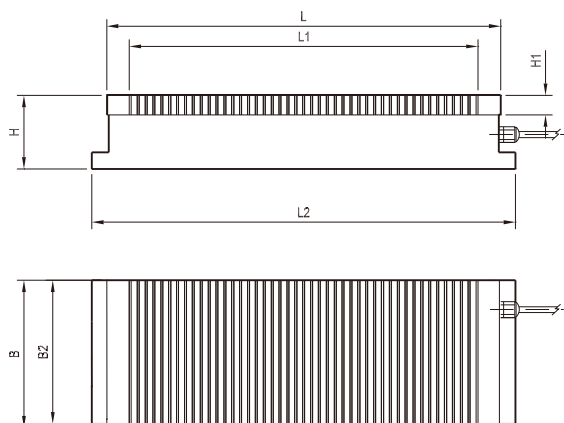

● Micropitch electromagnetic chuck with transverse poles

Use:

Clamping of transverse placed thin plate shaped workpieces

Features:

- EME with pole pitch 0.5+1.5 mm
- Highest uniform clamping force up to 120 N/cm²
- Top plate with micropitch transverse lamination
- Flux depth of only 4 mm
- Mono-block housing for maximum stability



Model	Width (B)	Length (L)	Base Width (B2)	Base Length (L2)	Height (H)	L1	H1	Voltage	Current	Net Weight
EME-1525	150 (5.91)	250 (9.85)	148 (5.83)	270 (10.63)	90 (3.54)	214 (8.43)	30 (1.18)	DC 110 V	0.72 A	25 kg / 55 lb
EME-1530	150 (5.91)	300 (11.82)	148 (5.83)	320 (12.60)	90 (3.54)	264 (10.40)	30 (1.18)	DC 110 V	0.62 A	30 kg / 66 lb
EME-1535	150 (5.91)	350 (13.79)	148 (5.83)	370 (11.57)	90 (3.54)	314 (12.37)	30 (1.18)	DC 110 V	0.80 A	35 kg / 78 lb
EME-1540	150 (5.91)	400 (15.76)	148 (5.83)	420 (16.54)	90 (3.54)	364 (14.34)	30 (1.18)	DC 110 V	0.70 A	40 kg / 89 lb
EME-1545	150 (5.91)	450 (17.73)	148 (5.83)	470 (18.50)	90 (3.54)	414 (16.31)	30 (1.18)	DC 110 V	1.00 A	45 kg / 100 lb
EME-1840	180 (7.09)	400 (15.76)	178 (7.01)	420 (16.54)	90 (3.54)	364 (14.34)	30 (1.18)	DC 110 V	0.94 A	48 kg / 106 lb
EME-2040	200 (7.88)	400 (15.76)	198 (7.80)	420 (16.54)	90 (3.54)	364 (14.34)	30 (1.18)	DC 110 V	1.00 A	54 kg / 118 lb
EME-2045	200 (7.88)	450 (17.73)	198 (7.80)	470 (18.50)	90 (3.54)	414 (16.31)	30 (1.18)	DC 110 V	1.10 A	60 kg / 133 lb
EME-2050	200 (7.88)	500 (19.70)	198 (7.80)	520 (20.47)	90 (3.54)	440 (17.34)	30 (1.18)	DC 110 V	1.30 A	67 kg / 148 lb
EME-2060	200 (7.88)	600 (23.64)	198 (7.80)	620 (24.41)	90 (3.54)	554 (21.83)	30 (1.18)	DC 110 V	1.10 A	81 kg / 177 lb
EME-2550	250 (9.85)	500 (19.70)	248 (9.77)	520 (20.47)	90 (3.54)	440 (17.34)	30 (1.18)	DC 110 V	1.70 A	84 kg / 185 lb
EME-2560	250 (9.85)	600 (23.64)	248 (9.77)	620 (24.41)	90 (3.54)	554 (21.83)	30 (1.18)	DC 110 V	1.90 A	101 kg / 221 lb
EME-3060	300 (11.82)	600 (23.64)	298 (11.74)	620 (24.41)	90 (3.54)	554 (21.83)	30 (1.18)	DC 110 V	1.90 A	121 kg / 266 lb
EME-4080	400 (15.76)	800 (31.52)	398 (15.68)	820 (32.28)	90 (3.54)	745 (29.33)	30 (1.18)	DC 110 V	2.80 A	215 kg / 473 lb
EME-5080	500 (19.70)	800 (31.52)	498 (19.62)	820 (32.28)	90 (3.54)	745 (29.33)	30 (1.18)	DC 110 V	3.20 A	268 kg / 591 lb

Unit: mm(in)

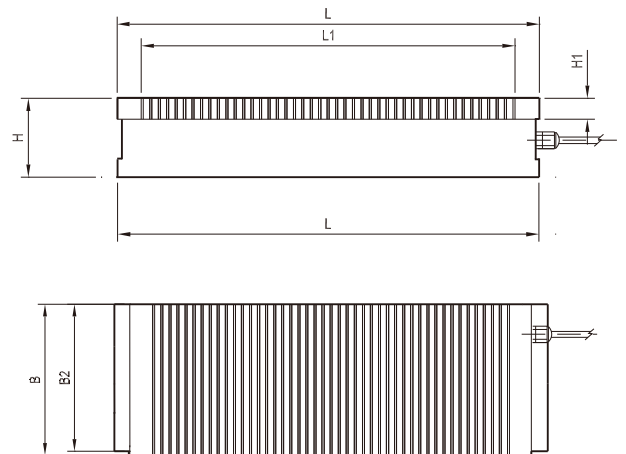

● **Mircopitch electro-permanent magnetic chuck with transverse poles**

Use:

Clamping of transverse placed thin plate shaped workpieces

Features:

- EPB with pole pitch 1+3 mm
- Highest uniform clamping force up to 120 N/cm²
- Electro-permanent technology with no deformation owing to the rise of temperature
- Can eliminate residual magnetism from the workpiece
- Coolant and water proof structure
- Minimum mechanical deformation with solid one-piece housing

Model	Width (B)	Length (L)	Base Width (B2)	Height (H)	L1	H1	Net Weight	Controller (400V)	Controller (220V)
EPB-1525	150 (5.91)	250 (9.85)	148 (5.83)	85 (3.35)	214 (8.43)	30 (1.18)	24 kg / 52 lb	CGA	CGA
EPB-1530	150 (5.91)	300 (11.82)	148 (5.83)	85 (3.35)	264 (10.40)	30 (1.18)	29 kg / 63 lb	CGA	CGA
EPB-1535	150 (5.91)	350 (13.79)	148 (5.83)	85 (3.35)	314 (12.37)	30 (1.18)	33 kg / 73 lb	CGA	CGA
EPB-1540	150 (5.91)	400 (15.76)	148 (5.83)	85 (3.35)	364 (14.34)	30 (1.18)	38 kg / 84 lb	CGA	CGA
EPB-1545	150 (5.91)	450 (17.73)	148 (5.83)	85 (3.35)	414 (16.31)	30 (1.18)	43 kg / 94 lb	CGA	CGA
EPB-1840	180 (7.09)	400 (15.76)	178 (7.01)	85 (3.35)	364 (14.34)	30 (1.18)	46 kg / 100 lb	CGA	CGA
EPB-2040	200 (7.88)	400 (15.76)	198 (7.80)	85 (3.35)	364 (14.34)	30 (1.18)	51 kg / 112 lb	CGA	CGA
EPB-2045	200 (7.88)	450 (17.73)	198 (7.80)	85 (3.35)	414 (16.31)	30 (1.18)	57 kg / 126 lb	CGA	CGA
EPB-2050	200 (7.88)	500 (19.70)	198 (7.80)	85 (3.35)	464 (18.27)	30 (1.18)	63 kg / 139 lb	CGA	CGA
EPB-2060	200 (7.88)	600 (23.64)	198 (7.80)	85 (3.35)	564 (22.20)	30 (1.18)	76 kg / 167 lb	CGA	CGA
EPB-2550	250 (9.85)	500 (19.70)	248 (9.77)	85 (3.35)	464 (18.27)	30 (1.18)	79 kg / 174 lb	CGA	CGA
EPB-2560	250 (9.85)	600 (23.64)	248 (9.77)	85 (3.35)	564 (22.20)	30 (1.18)	95 kg / 209 lb	CGA	CGA
EPB-3060	300 (11.82)	600 (23.64)	298 (11.74)	85 (3.35)	564 (22.20)	30 (1.18)	114 kg / 251 lb	CGA	CGA
EPB-3080	300 (11.82)	800 (31.52)	298 (11.74)	85 (3.35)	764 (30.08)	30 (1.18)	152 kg / 335 lb	CGA	CGA
EPB-30100	300 (11.82)	1000 (39.40)	298 (11.74)	85 (3.35)	964 (37.95)	30 (1.18)	190 kg / 418 lb	CGA	CGA
EPB-30120	300 (11.82)	1200 (47.28)	298 (11.74)	85 (3.35)	1164 (45.83)	30 (1.18)	228 kg / 502 lb	CGA	CGA
EPB-4060	400 (15.76)	600 (23.64)	398 (15.68)	85 (3.35)	564 (22.20)	30 (1.18)	203 kg / 446 lb	CGA	CGA
EPB-4080	400 (15.76)	800 (31.52)	398 (15.68)	85 (3.35)	764 (30.08)	30 (1.18)	254 kg / 558 lb	CGA	CGA

Unit: mm(in)



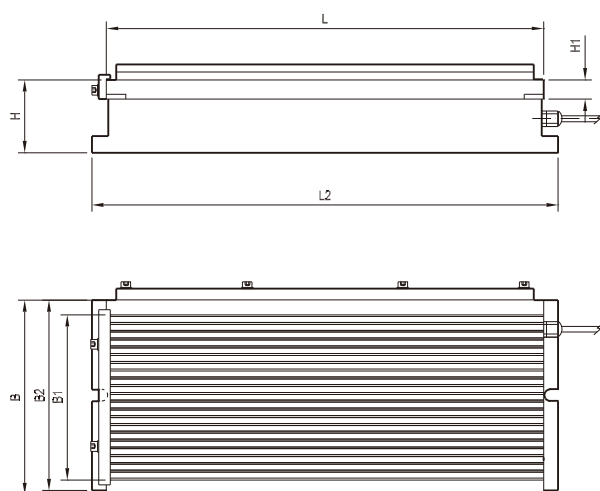

● micropitch electromagnetic chuck with longitudinal poles

Use:

Clamping of longitudinal placed thin plate shaped workpieces

Features:

- EMM with pole pitch 0.5+1.5 mm
- Highest uniform clamping force up to 120 N/cm²
- Top plate with micropitch longitudinal lamination
- Full surface magnetic power
- Low magnetic field height of only 4 mm
- Minimum mechanical deformation with solid one-piece housing
- Low current with minimum power consumption

Model	Width(B)	Length(L)	B2	L2	Height(H)	B1	H1	Voltage	Current	Net Weight
EMM-1530	150 (5.91)	300 (11.81)	148 (5.83)	330 (12.99)	75 (2.95)	117 (4.61)	20 (0.79)	DC 110 V	0.6 A	23 kg / 51 lb
EMM-1535	150 (5.91)	350 (13.78)	148 (5.83)	380 (14.96)	75 (2.95)	117 (4.61)	20 (0.79)	DC 110 V	0.7 A	27 kg / 59 lb
EMM-1540	150 (5.91)	400 (15.75)	148 (5.83)	430 (16.93)	75 (2.95)	117 (4.61)	20 (0.79)	DC 110 V	0.8 A	31 kg / 68 lb
EMM-1545	150 (5.91)	450 (17.72)	148 (5.83)	480 (18.90)	75 (2.95)	117 (4.61)	20 (0.79)	DC 110 V	0.9 A	34 kg / 75 lb
EMM-2040	200 (7.87)	400 (15.75)	198 (7.80)	430 (16.93)	75 (2.95)	165 (6.50)	20 (0.79)	DC 110 V	1.0 A	41 kg / 90 lb
EMM-2045	200 (7.87)	450 (17.72)	198 (7.80)	480 (18.90)	75 (2.95)	165 (6.50)	20 (0.79)	DC 110 V	1.2 A	46 kg / 101 lb
EMM-2050	200 (7.87)	500 (19.69)	198 (7.80)	530 (20.87)	75 (2.95)	165 (6.50)	20 (0.79)	DC 110 V	1.5 A	51 kg / 112 lb
EMM-2550	250 (9.84)	500 (19.69)	248 (9.76)	530 (20.87)	75 (2.95)	214 (8.43)	20 (0.79)	DC 110 V	1.7 A	64 kg / 141 lb
EMM-3060	300 (11.81)	600 (23.62)	298 (11.73)	630 (24.80)	75 (2.95)	260 (10.24)	20 (0.79)	DC 110 V	1.9 A	94 kg / 207 lb
EMM-4080	400 (15.75)	800 (31.50)	398 (15.67)	830 (32.68)	75 (2.95)	354 (13.94)	20 (0.79)	DC 110 V	2.8 A	171 kg / 376 lb

Unit: mm(in)

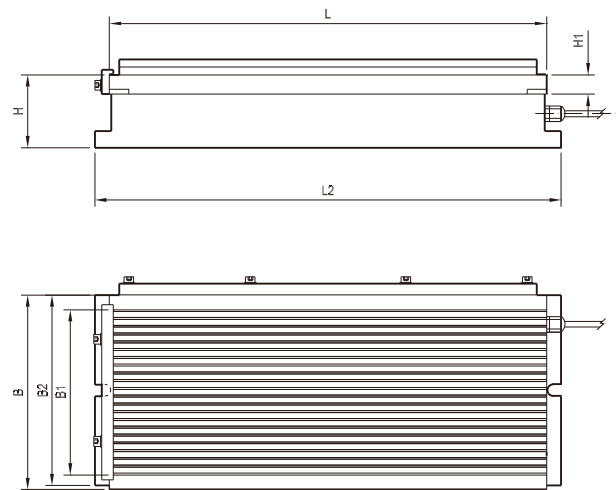

Grinding

● **Micropitch electro-permanent magnetic chuck with longitudinal poles**

Use:

Clamping of longitudinal placed thin plate shaped workpieces

Features:

- EPM with pole pitch 1+3 mm
- Highest uniform clamping force up to 120 N/cm²
- Electro-permanent magnetic technology with no deformation owing to the rise of temperature
- Top plate with micropitch longitudinal lamination
- Full surface magnetic power
- Minimum mechanical deformation with solid one-piece housing

Model	Width(B)	Length(L)	B2	L2	Height(H)	B1	H1	Controller (400V)	Controller (220V)	Net Weight
EPM-1530	150 (5.91)	300 (11.81)	148 (5.83)	330 (12.99)	75 (2.95)	117 (4.61)	20 (0.79)	CGA	CGA	23 kg / 51 lb
EPM-1535	150 (5.91)	350 (13.78)	148 (5.83)	380 (14.96)	75 (2.95)	117 (4.61)	20 (0.79)	CGA	CGA	27 kg / 59 lb
EPM-1540	150 (5.91)	400 (15.75)	148 (5.83)	430 (16.93)	75 (2.95)	117 (4.61)	20 (0.79)	CGA	CGA	31 kg / 68 lb
EPM-1545	150 (5.91)	450 (17.72)	148 (5.83)	480 (18.90)	75 (2.95)	117 (4.61)	20 (0.79)	CGA	CGA	34 kg / 75 lb
EPM-2040	200 (7.87)	400 (15.75)	198 (7.80)	430 (16.93)	75 (2.95)	165 (6.50)	20 (0.79)	CGA	CGA	41 kg / 90 lb
EPM-2045	200 (7.87)	450 (17.72)	198 (7.80)	480 (18.90)	75 (2.95)	165 (6.50)	20 (0.79)	CGA	CGA	46 kg / 101 lb
EPM-2050	200 (7.87)	500 (19.69)	198 (7.80)	530 (20.87)	75 (2.95)	165 (6.50)	20 (0.79)	CGA	CGA	51 kg / 112 lb
EPM-2550	250 (9.84)	500 (19.69)	248 (9.76)	530 (20.87)	75 (2.95)	214 (8.43)	20 (0.79)	CGA	CGA	64 kg / 141 lb
EPM-3060	300 (11.81)	600 (23.62)	298 (11.73)	630 (24.80)	75 (2.95)	260 (10.24)	20 (0.79)	CGA	CGA	94 kg / 207 lb
EPM-4080	400 (15.75)	800 (31.50)	398 (15.67)	830 (32.68)	75 (2.95)	354 (13.94)	20 (0.79)	CGA	CGA	171 kg / 376 lb

Unit: mm(in)



• Square pole electro-permanent magnetic chuck with standard density

Use:

Clamping for grinding of medium to large work pieces

Features:

- Full metallic surface, no resin, coolant and water proof
- Square pole size 50x50 mm
- Magnetic force higher than 200 kg per pole
- Electro-permanent magnetic technology with no deformation owing to the rise of temperature
- Distortion free clamping with auto-shim pole extensions
- No residual magnetism
- Workpiece larger than the table size are possible
- Multiple magnet combinations can provide clamping for larger sizes
- Magnetic flux depth 12.5 mm



Fix pole extensions

ES fixed and ET self shimming pole extensions using the built in threaded rod which does not require tools to install or remove.

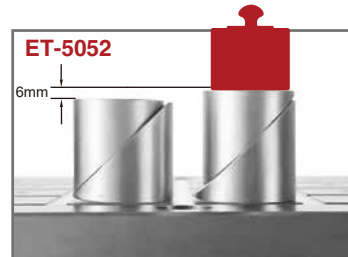

Mobile pole extensions

The new and improved ET pole extension has increased the performance of the original ET by 20%. Total adjustment is 6 mm.

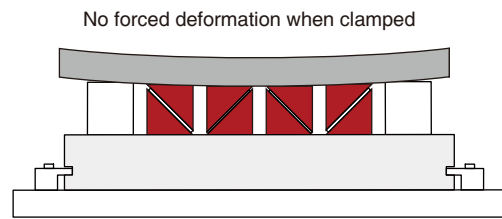
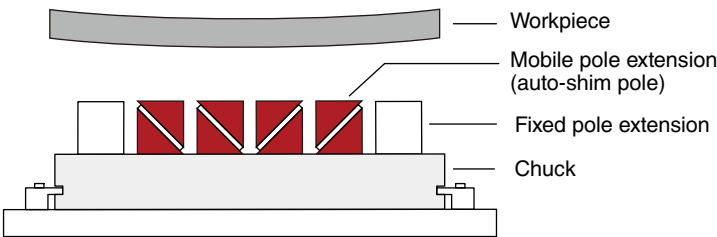

Model	Width	Length	Height	Pole No.	Controller (400/480V)	Controller (220V)	Net Weight
EPS-3049	300 (11.82)	490 (19.29)	59 (2.32)	24	CGA	CGA	75 kg / 165 lb
EPS-3064	300 (11.82)	640 (25.20)	59 (2.32)	32	CGA	CGA	98 kg / 216 lb
EPS-3649	360 (14.17)	490 (19.29)	59 (2.32)	30	CGA	CGA	78 kg / 172 lb
EPS-3664	360 (14.17)	640 (25.20)	59 (2.32)	40	CGA	CGA	101 kg / 222 lb
EPS-3679	360 (14.17)	790 (31.10)	59 (2.32)	50	CGA	CGA	125 kg / 276 lb
EPS-4279	420 (16.54)	790 (31.10)	59 (2.32)	60	CGA	CGD	146 kg / 322 lb
EPS-4894	480 (18.90)	940 (37.00)	59 (2.32)	84	CGA	CGD	199 kg / 439 lb
EPS-48109	480 (18.90)	1090 (42.91)	59 (2.32)	98	CGD	CGD	230 kg / 507 lb
EPS-5494	540 (21.26)	940 (37.00)	59 (2.32)	96	CGD	CGD	258 kg / 569 lb
EPS-54109	540 (21.26)	1090 (42.91)	59 (2.32)	112	CGD	CGD	300 kg / 661 lb
EPS-60139	600 (23.62)	1390 (54.72)	59 (2.32)	162	CGD	CGF	367 kg / 809 lb
EPS-60154	600 (23.62)	1540 (60.63)	59 (2.32)	180	CGF	CGF	407 kg / 897lb
EPS-66139	660 (25.98)	1390 (54.72)	59 (2.32)	170	CGF	CGF	404 kg / 899lb
EPS-66154	660 (25.98)	1540 (60.63)	59 (2.32)	188	CGF	CGF	450 kg / 992lb

Unit: mm(in)

PMF

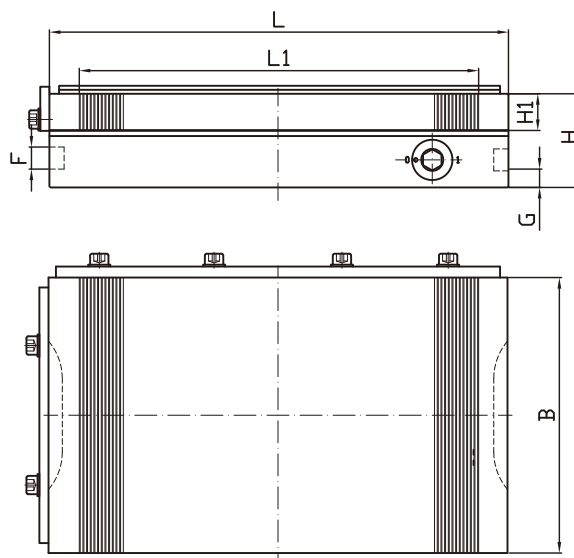

Grinding

• Permanent magnetic chuck

Use:

General purpose low profile grinding magnet

Features:

- PMF with pole pitch 0.5+1.5 mm
- Highest uniform magnetic clamping force up to 120 N/cm²
- Coolant and water proof structure
- Easy to activate and de-activate
- High precision with no residual magnetism



Model	Width(B)	Length(L)	Height(H)	L1	H1	F	G	Net Weight
PMF-0713	70 (2.76)	130 (5.12)	49 (1.93)	101 (3.98)	20 (0.79)	10 (0.39)	10 (0.39)	3 kg / 8 lb
PMF-10175	100 (3.94)	175 (6.90)	49 (1.93)	140 (5.51)	20 (0.79)	10 (0.39)	10 (0.39)	7 kg / 15 lb
PMF-1025	100 (3.94)	250 (9.84)	49 (1.93)	206 (8.11)	20 (0.79)	10 (0.39)	10 (0.39)	10 kg / 21 lb
PMF-1325	130 (5.12)	255 (10.03)	49 (1.93)	206 (8.11)	20 (0.79)	10 (0.39)	10 (0.39)	12 kg / 27 lb
PMF-1340	130 (5.12)	400 (15.75)	49 (1.93)	357 (14.06)	20 (0.79)	10 (0.39)	10 (0.39)	20 kg / 44 lb
PMF-1426	140 (5.52)	260 (10.24)	51 (2.01)	216 (8.50)	20 (0.79)	10 (0.39)	10 (0.39)	14 kg / 32 lb
PMF-1515	150 (5.90)	150 (5.91)	51 (2.02)	108 (4.25)	20 (0.79)	10 (0.39)	10 (0.39)	9 kg / 20 lb
PMF-1525	150 (5.91)	250 (9.84)	51 (2.01)	206 (8.11)	20 (0.79)	10 (0.39)	10 (0.39)	15 kg / 33 lb
PMF-1530	150 (5.91)	300 (11.81)	51 (2.01)	257 (10.12)	20 (0.79)	10 (0.39)	10 (0.39)	18 kg / 39 lb
PMF-1535	150 (5.91)	350 (13.78)	51 (2.01)	305 (12.01)	20 (0.79)	10 (0.39)	10 (0.39)	21 kg / 46 lb
PMF-1540	150 (5.91)	400 (15.75)	51 (2.01)	357 (14.06)	20 (0.79)	10 (0.39)	10 (0.39)	24 kg / 53 lb
PMF-1545	150 (5.91)	450 (17.72)	51 (2.01)	407 (17.34)	20 (0.79)	10 (0.39)	10 (0.39)	27 kg / 59 lb
PMF-2030	200 (7.88)	300 (11.81)	51 (2.01)	257 (10.12)	20 (0.79)	10 (0.39)	10 (0.39)	24 kg / 53 lb
PMF-2035	200 (7.88)	350 (13.78)	51 (2.01)	305 (12.01)	20 (0.79)	10 (0.39)	10 (0.39)	28 kg / 61 lb
PMF-2040	200 (7.88)	400 (15.75)	51 (2.01)	357 (14.06)	20 (0.79)	10 (0.39)	10 (0.39)	32 kg / 70 lb
PMF-2045	200 (7.88)	450 (17.72)	51 (2.01)	407 (17.34)	20 (0.79)	10 (0.39)	10 (0.39)	36 kg / 79 lb
PMF-2050	200 (7.88)	500 (19.69)	51 (2.01)	454 (17.87)	20 (0.79)	10 (0.39)	10 (0.39)	40 kg / 88 lb
PMF-2060	200 (7.88)	600 (23.62)	51 (2.01)	556 (21.89)	20 (0.79)	10 (0.39)	10 (0.39)	48 kg / 105 lb
PMF-2063	200 (7.88)	630 (24.80)	51 (2.01)	586 (23.07)	20 (0.79)	10 (0.39)	10 (0.39)	50 kg / 110 lb
PMF-2535	250 (9.85)	350 (13.79)	51 (2.01)	305 (12.01)	20 (0.79)	10 (0.39)	10 (0.39)	33 kg / 73 lb
PMF-2540	250 (9.85)	400 (15.76)	51 (2.01)	357 (14.06)	20 (0.79)	10 (0.39)	10 (0.39)	38 kg / 84 lb
PMF-2550	250 (9.85)	500 (19.70)	51 (2.01)	454 (17.87)	20 (0.79)	10 (0.39)	10 (0.39)	48 kg / 105 lb
PMF-2563	250 (9.85)	630 (24.82)	51 (2.01)	586 (23.07)	24 (0.94)	10 (0.39)	10 (0.39)	60 kg / 132 lb
PMF-3040	300 (11.82)	400 (15.76)	56 (2.20)	357 (14.06)	24 (0.94)	10 (0.39)	10 (0.39)	52 kg / 115 lb
PMF-3050	300 (11.82)	500 (19.70)	56 (2.20)	454 (17.87)	24 (0.94)	10 (0.39)	10 (0.39)	66 kg / 144 lb
PMF-3060	300 (11.82)	600 (23.64)	56 (2.20)	556 (21.89)	24 (0.94)	10 (0.39)	10 (0.39)	79 kg / 173 lb
PMF-3063	300 (11.82)	630 (24.82)	56 (2.20)	586 (23.07)	24 (0.94)	10 (0.39)	10 (0.39)	83 kg / 182 lb
PMF-4060	400 (15.76)	600 (23.64)	56 (2.20)	556 (21.89)	22 (0.87)	10 (0.39)	10 (0.39)	106 kg / 233 lb

Unit: mm(in)

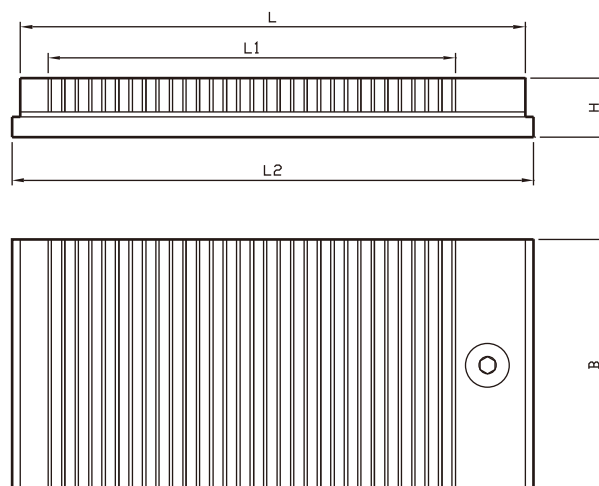

● Permanent magnetic low profile chuck

Use:

For spark erosion and precision grinding of small and thin workpieces

Features:

- Pole pitch 0.5+1.5 mm
- Max. magnetic clamping force up to 120 N/cm²
- Low profile with activation from top surface
- Suitable for adaption on zero reference system
- Low flux depth of 6mm and no residual magnetism
- EDM can be performed close to surface without magnetic interference

Model	Width(B)	Length(L)	Base Length(L2)	Height(H)	L1	Net Weight
PMT-0713	70 (2.76)	130 (5.12)	140 (5.51)	32 (1.26)	67(2.64)	4 kg / 9 lb
PMT-10175	100 (3.94)	175 (6.89)	185 (7.28)	32 (1.26)	117(4.61)	5 kg / 11 lb
PMT-1325	130 (5.12)	250 (9.84)	260 (10.24)	35 (1.38)	192 (7.56)	9 kg / 20 lb
PMT-1515	150 (5.91)	150 (5.91)	160 (6.30)	35 (1.38)	92(3.62)	6 kg / 13 lb
PMT-1525	150 (5.91)	250 (9.84)	260 (10.24)	35 (1.38)	192 (7.56)	10 kg / 22 lb
PMT-1530	150 (5.91)	300 (11.81)	310 (12.20)	35 (1.38)	242 (9.53)	12 kg / 26 lb
PMT-1535	150 (5.91)	350 (13.78)	360 (14.17)	35 (1.38)	292 (11.50)	14 kg / 31 lb
PMT-1545	150 (5.91)	450 (17.72)	460 (18.11)	35 (1.38)	392 (15.43)	18 kg / 40 lb
PMT-2030	200 (7.87)	300 (11.81)	310 (12.20)	35 (1.38)	242 (9.53)	16 kg / 35 lb
PMT-2040	200 (7.87)	400 (15.75)	410 (16.14)	35 (1.38)	342 (13.46)	23 kg / 51lb
PMT-2050	200 (7.87)	500 (19.69)	510 (20.08)	35 (1.38)	442 (17.40)	27 kg / 59 lb
PMT-2535	250 (9.84)	350 (13.78)	360 (14.17)	35 (1.38)	292 (11.50)	24 kg / 53 lb
PMT-3030	300 (11.81)	300 (11.81)	310 (12.20)	35 (1.38)	242 (9.53)	24 kg / 53 lb
PMT-3040	300 (11.81)	400 (15.75)	410 (16.14)	35 (1.38)	342 (13.46)	32 kg / 70 lb

Unit: mm(in)

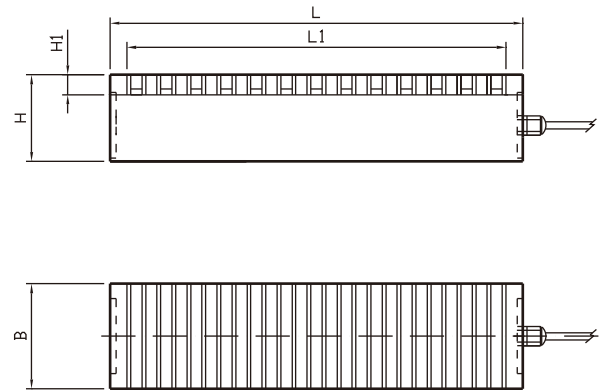

Grinding

● **Standard pitch electromagnetic chuck**

Use:
Clamping for knife grinding

- Features:**
- Pole pitch 3+16 mm
 - Highest clamping force up to 150 N/cm²
 - Solid top plate with high precision
 - Real magnetic poles
 - Minimum mechanical deformation with solid one-piece housing
 - Low current with minimum power consumption

Model	Width (B)	Length (L)	Height (H)	L1	H1	Voltage	Current	Net Weight
EMK-1167	128 (5.04)	665 (26.18)	96 (3.78)	574 (22.60)	21 (083)	DC 110 V	0.9A	61 kg / 133 lb
EMK-16160	160 (6.30)	1600 (62.99)	150 (5.91)	1542 (60.71)	30 (1.18)	DC 110 V	1.0A	285 kg / 626 lb
EMK-18160	180 (7.09)	1600 (62.99)	150 (5.91)	1542 (60.71)	30 (1.18)	DC 110 V	1.1A	320 kg / 704 lb
EMK-20100	200 (7.87)	1000 (39.37)	150 (5.91)	934 (36.77)	30 (1.18)	DC 110 V	1.1A	223 kg / 491 lb
EMK-20150	200 (7.87)	1500 (59.06)	150 (5.91)	1433 (56.42)	30 (1.18)	DC 110 V	1.2A	333 kg / 734 lb
EMK-20180	200 (7.87)	1800 (70.87)	150 (5.91)	1732 (68.19)	30 (1.18)	DC 110 V	1.5A	400 kg / 880 lb

Unit: mm(in)

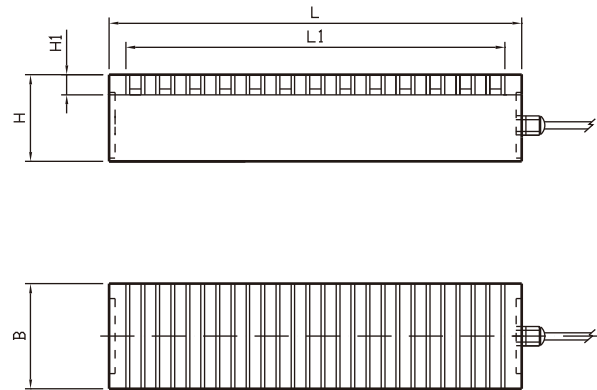

• Standard pitch electro-permanent magnetic chuck

Use:
Clamping for knife grinding

- Features:**
- Pole pitch 3+16 mm
 - Highest clamping force up to 150 N/cm²
 - Electro-permanent magnetic technology with no deformation owing to the rise of temperature
 - Solid top plate with high precision
 - Real magnetic poles
 - Minimum mechanical deformation with solid one-piece housing

Model	Width (B)	Length (L)	Height (H)	L1	H1	Net Weight	Controller(400V)
EPZ-1167	128 (5.04)	665 (26.18)	96 (3.78)	574 (22.60)	21 (083)	61 kg / 133 lb	CGA
EPZ-16160	160 (6.30)	1600 (62.99)	150 (5.91)	1542 (60.71)	30 (1.18)	285 kg / 626 lb	CGA
EPZ-18160	180 (7.09)	1600 (62.99)	150 (5.91)	1542 (60.71)	30 (1.18)	320 kg / 704 lb	CGA
EPZ-20100	200 (7.87)	1000 (39.37)	150 (5.91)	934 (36.77)	30 (1.18)	223 kg / 491 lb	CGA
EPZ-20150	200 (7.87)	1500 (59.06)	150 (5.91)	1433 (56.42)	30 (1.18)	333 kg / 734 lb	CGA
EPZ-20180	200 (7.87)	1800 (70.87)	150 (5.91)	1732 (68.19)	30 (1.18)	400 kg / 880 lb	CGA

Unit: mm(in)

PPN / PPA



• Pallet chuck

Use:

Clamping for heavy machining for medium to large work pieces

Features:

- Square pole size 50x50 mm
- Magnetic force higher than 350 kg per pole
- Electro-permanent technology with no deformation owing to the rise of temperature
- Distortion free clamping with auto-shim pole extensions
- No residual magnetism
- Controlled flux prevents magnetization of the tool
- Workpiece larger than the table size are machinable

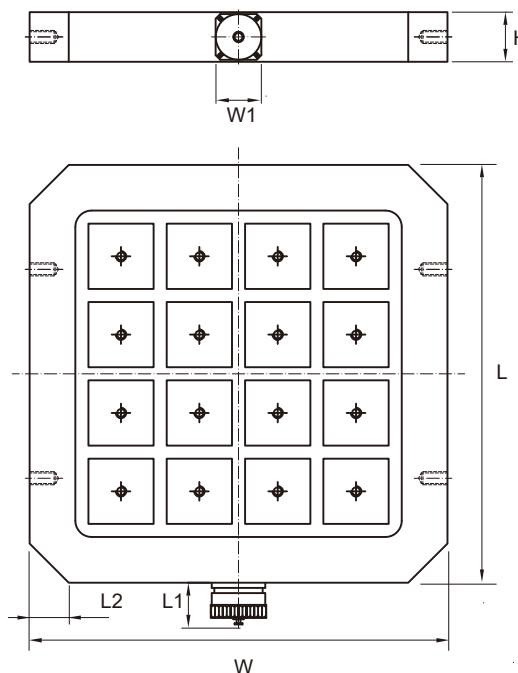

Model	Width(W)	Length(L)	Height(H)	W1	L1	L2	Controller (220/400V)	Net Weight
PPN 3232	320 (12.60)	320 (12.60)	38 (1.50)	35 (1.38)	35 (1.38)	30 (1.18) x 45°	CUA	30 kg / 66 lb

Unit: mm(in)



• Pallet chuck

Use:

For zero point clamping systems

Features:

- Aluminium housing
- Pole pitch 5+3 mm
- Two switchable sections
- Max magnetic clamping force up to 160 N/cm²
- Low magnetic flux

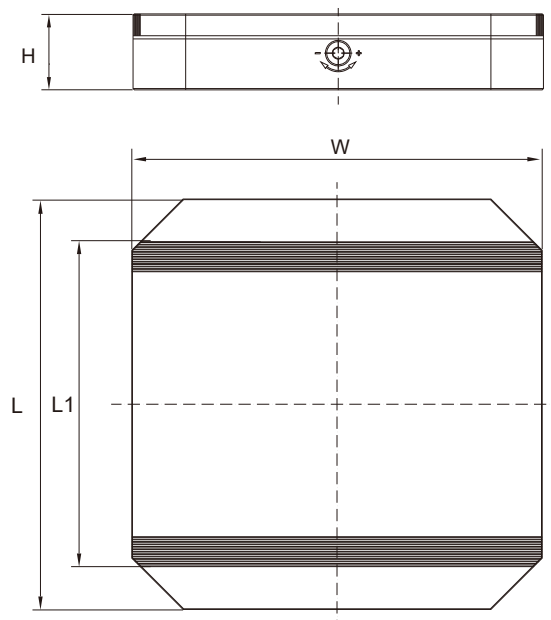

Model	Width(W)	Length(L)	Height(H)	L1	Net Weight
PPA 2424	240 (9.45)	240 (9.45)	60 (2.36)	174 (6.85)	19.5 kg / 43 lb
PPA 2828	280 (11.02)	280 (11.02)	60 (2.36)	214 (8.43)	22 kg / 49 lb
PPA 3232	320 (12.60)	320 (12.60)	60 (2.36)	254 (10)	26 kg / 57 lb

Unit: mm(in)

PPC / PPM



• Pallet chuck

Use:

Clamping for palletizing system

Features:

- Pole pitch 0.5+1.5 mm
- Max magnetic clamping force up to 120 N/cm²
- No residual magnetism
- High precision and low flux depth 6 mm
- Very light switching force
- High accuracy guaranteed through entire service life

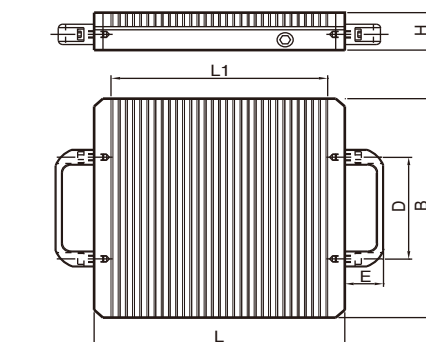

Model	Width (B)	Length(L)	Height(H)	L1	D	E	Net Weight
PPC-2424/40	240 (9.45)	240 (9.45)	40 (1.57)	197 (7.76)	130 (5.12)	40 (1.57)	16 kg / 35 lb
PPC-2828/40	280 (11.02)	280 (11.02)	40 (1.57)	237 (9.33)	130 (5.12)	40 (1.57)	22 kg / 48 lb
PPC-3232/40	320 (12.60)	320 (12.60)	40 (1.57)	279 (10.98)	130 (5.12)	40 (1.57)	28 kg / 62 lb

Unit: mm(in)

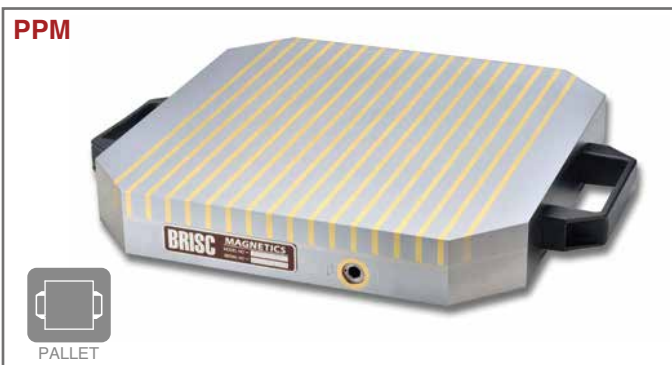

• Pallet chuck

Use:

Clamping for palletizing system

Features:

- Pole pitch 4+11 mm
- Max. Magnetic clamping force up to 180 N/cm²
- No residual magnetism
- Strong clamping force with low flux depth 12 mm
- Easy to activate and de-activate
- High accuracy guaranteed through entire service life

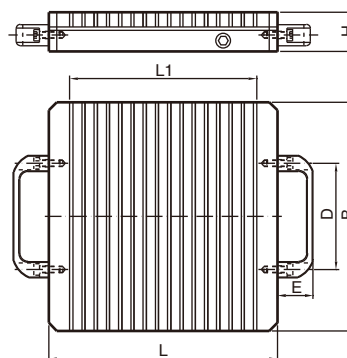

Model	Width(B)	Length(L)	Height(H)	L1	D	E	Net Weight
PPM-2424-48	240 (9.45)	240 (9.45)	48 (1.89)	184 (7.24)	130 (5.12)	40 (1.57)	19 kg / 42 lb
PPM-2828-48	280 (11.02)	280 (11.02)	48 (1.89)	214 (8.43)	130 (5.12)	40 (1.57)	20 kg / 57 lb
PPM-3232-48	320 (12.60)	320 (12.60)	48 (1.89)	259 (10.20)	130 (5.12)	40 (1.57)	35 kg / 77 lb

Unit: mm(in)

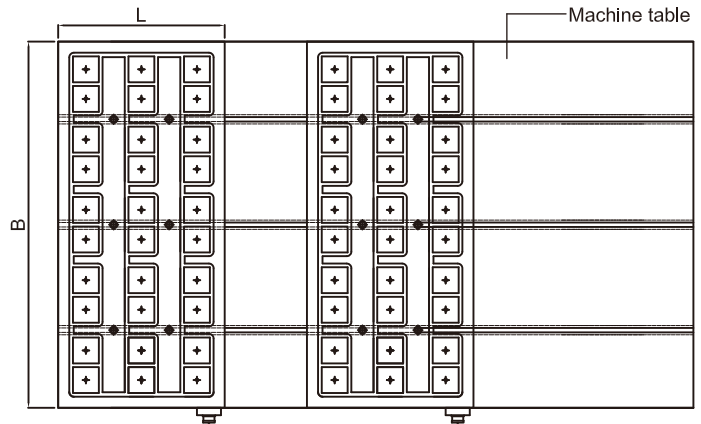

● Electro-permanent magnetic chuck for bridge type machining center

Use:

Clamping for heavy machining for medium to large work pieces

Features:

- Square pole size 70x70 mm
- Magnetic force higher than 690 kg per pole
- Electro-permanent technology with no deformation owing to the rise of temperature
- Distortion free clamping with auto-shim pole extensions
- No residual magnetism
- Controlled flux prevents magnetization of the tool
- Workpiece larger than the table size are machinable
- Multiple magnet combinations can provide clamping for any bridge type machining center.



Model	Width (B)	Length (L)	Height(H)	Pole No.	Net Weight	Controller (220V)	Controller (400/480V)
XP70-9945	990 (38.98)	450 (17.72)	80 (3.15)	30	266 kg / 585 lb	CUA	CUA
XP70-11845	1180 (46.46)	450 (17.72)	80 (3.15)	36	317 kg / 697 lb	CUA	CUA
XP70-13745	1370 (53.94)	450 (17.72)	80 (3.15)	42	368 kg / 809 lb	CUD	CUA
XP70-15630	1560 (61.42)	300 (11.81)	80 (3.15)	32	279 kg / 615 lb	CUA	CUA
XP70-17530	1750 (68.9)	300 (11.81)	80 (3.15)	36	313 kg / 690 lb	CUA	CUA

Unit: mm(in)

Pole Extension

	EV-7020 70x70 mm fix pole extension with height 20 mm		EW-7020 70x70 mm fix pole extension with height 20 mm and step		EX-7020 70x70 mm fix pole extension with height 20 mm and step
	ES-7070 Diameter 70 mm fix pole extension with height 52 mm		ET-7070 Diameter 70 mm auto-shim pole extension with height 52 mm		EE-7020 70x70 mm fix pole extension with height 20 mm and step
	EA-7020 70x70 mm fix pole extension with height 20 mm		EA-7070 70x70 mm fix pole extension with height 50 mm		EC-7070 70x70 mm auto-shim pole extension with height 50 mm



• Square pole electro-permanent magnetic chuck with standard density

Use:

Clamping for heavy machining for medium to large work pieces

Features:

- Square pole size 50x50 mm
- Magnetic force higher than 350 kg per pole
- Electro-permanent technology with no deformation owing to the rise of temperature
- Distortion free clamping with auto-shim pole extensions
- No residual magnetism
- Controlled flux prevents magnetization of the tool
- Flux depth 12 mm
- Workpiece larger than the table size are machinable
- Multiple magnet combinations can provide clamping for any table size, large or small



Model	Width	Length	Height	Pole No.	Net Weight	Controller (220V)	Controller (400/480V)
PSP-3634	360 (14.17)	340 (13.39)	59 (2.32)	20	56 kg / 123 lb	CUA	CUA
PSP-3649	360 (14.17)	490 (19.29)	59 (2.32)	30	82 kg / 180 lb	CUA	CUA
PSP-3664	360 (14.17)	640 (25.20)	59 (2.32)	40	107 kg / 235 lb	CUA	CUA
PSP-3679	360 (14.17)	790 (31.10)	59 (2.32)	50	133 kg / 293 lb	CUA	CUA
PSP-4264	420 (16.54)	640 (25.20)	59 (2.32)	48	126 kg / 277 lb	CUA	CUA
PSP-4279	420 (16.54)	790 (31.10)	59 (2.32)	60	156 kg / 343 lb	CUD	CUA
PSP-4294	420 (16.54)	940 (37.01)	59 (2.32)	72	186 kg / 410 lb	CUD	CUA
PSP-42109	420 (16.54)	1090 (42.91)	59 (2.32)	84	215 kg / 473 lb	CUD	CUA
PSP-4864	480 (18.90)	640 (25.20)	59 (2.32)	56	144 kg / 317 lb	CUA	CUA
PSP-4879	480 (18.90)	790 (31.10)	59 (2.32)	70	178 kg / 392 lb	CUD	CUA
PSP-4894	480 (18.90)	940 (37.01)	59 (2.32)	84	212 kg / 467 lb	CUD	CUA
PSP-48109	480 (18.90)	1090 (42.91)	59 (2.32)	98	246 kg / 542 lb	CUD	CUD
PSP-6064	600 (23.62)	640 (25.20)	59 (2.32)	72	180 kg / 396 lb	CUD	CUA
PSP-6079	600 (23.62)	790 (31.10)	59 (2.32)	90	223 kg / 491 lb	CUD	CUD
PSP-6094	600 (23.62)	940 (37.01)	59 (2.32)	108	265 kg / 584 lb	CUD	CUD
PSP-60109	600 (23.62)	1090 (42.91)	59 (2.32)	126	308 kg / 679 lb		CUD

Unit: mm(in)

Pole Extension

Milling

• **Fix pole extensions**

• **Auto-shim pole extensions**

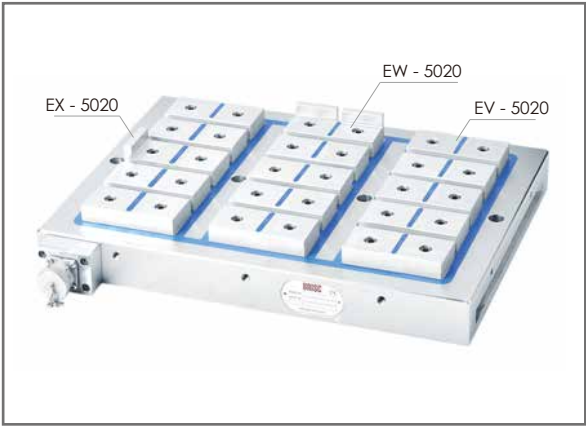

EV-5020
50x50 mm fix pole extension with height 20 mm



EW-5020
50x50 mm fix pole extension with height 20 mm and step



ES-5020
50x50 mm fix pole extension with height 20 mm and step



ES-5052
Diameter 50 mm fix pole extension with height 52 mm



ET-5052
Diameter 50 mm auto-shim pole extension with height 52 mm



EE-5020
50x50 mm fix pole extension with height 20 mm and step



EA-5020
50x50 mm fix pole extension with height 20 mm



EA-5050
50x50 mm fix pole extension with height 50 mm



EC-5050
50x50 mm auto-shim pole extension with height 50 mm



Fix pole extensions
ES fixed and ET self shimming pole extensions using the built in threaded rod which does not require tools to install or remove.

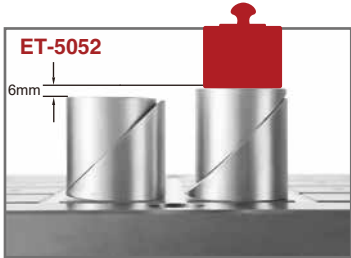

Mobile pole extensions
The new and improved ET pole extension has increased the performance of the original ET by 20%. Total adjustment is 6 mm.

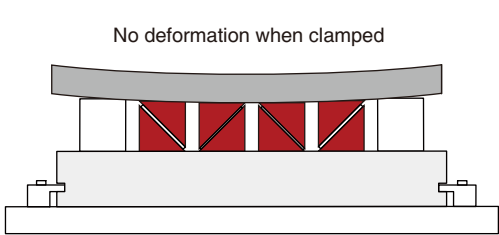
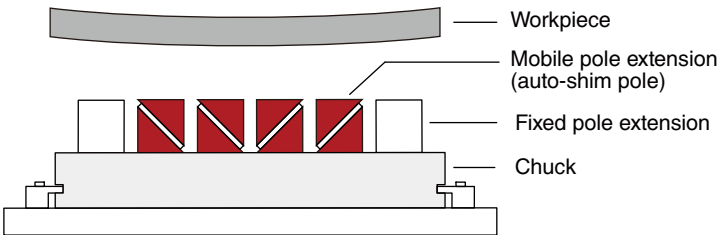

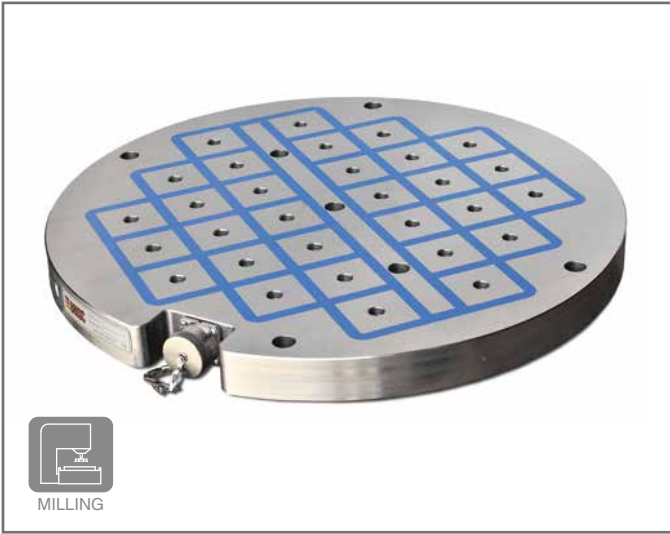

• Square pole electro-permanent magnetic chuck with standard density

Use:

Clamping for heavy machining for medium to large work pieces

Features:

- Square pole size 50x50 mm
- Magnetic force higher than 350 kg per pole
- Electro-permanent technology with no deformation owing to the rise of temperature
- Distortion free clamping with auto-shim pole extensions
- No residual magnetism
- Controlled flux prevents magnetization of the tool
- Flux depth 12 mm
- Workpiece larger than the table size are machinable

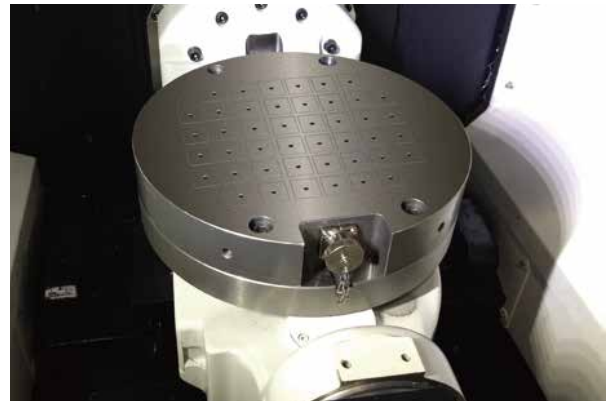

Model	Diameter	Height	Pole No.	Net Weight	Controller (220V)	Controller (400/480V)
PRP-400	400 (15.75)	45 (1.77)	21	42 kg / 92.6 lb	CUA	CUA
PRP-500	500 (19.69)	45 (1.77)	32	66 kg / 145.5 lb	CUA	CUA
PRP-600	600 (23.62)	45 (1.77)	52	95 kg / 209.4 lb	CUA	CUA
PRP-700	700 (27.56)	45 (1.77)	68	130 kg / 286.6 lb	CUD	CUA
PRP-800	800 (31.50)	45 (1.77)	96	170 kg / 374.8 lb	CUD	CUD
PRP-900	900 (35.43)	45 (1.77)	120	214 kg / 471.7 lb	CUF	CUD
PRP-1000	1000 (39.37)	45 (1.77)	156	265 kg / 584.2 lb	CUF	CUD

Unit: mm(in)

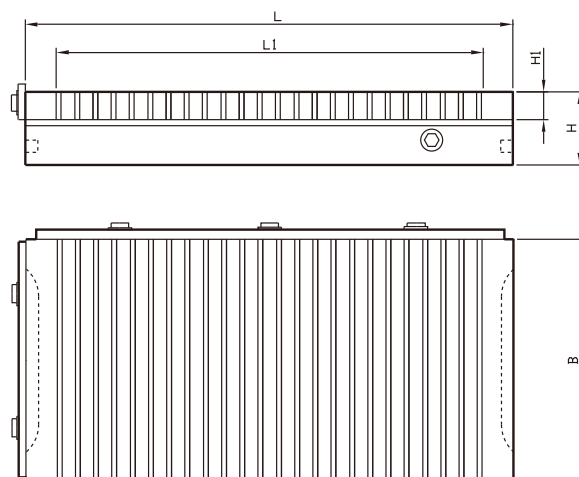

• Permanent magnetic chuck for milling

Use:

Clamping for heavy machining operation

Features:

- Pole pitch 4+11 mm
- Max. magnetic clamping force up to 180 N/cm²
- Highly concentrated magnetic field with low flux depth 6 mm
- Low flux depth prevents magnetization of the tooling
- Coolant and water proof structure
- Easy to activate and de-activate
- High precision with no residual magnetism



Model	Width(B)	Length(L)	Effective Length(L1)	Height(H)	H1	Net Weight
PMM-1525	150 (5.91)	250 (9.84)	199 (7.83)	56 (2.20)	23 (0.91)	16 kg / 34 lb
PMM-1530	150 (5.91)	300 (11.81)	259 (10.20)	56 (2.20)	23 (0.91)	19 kg / 41 lb
PMM-1535	150 (5.91)	350 (13.78)	304 (11.97)	56 (2.20)	23 (0.91)	22 kg / 48 lb
PMM-1545	150 (5.91)	450 (17.72)	409 (16.10)	56 (2.20)	23 (0.91)	28 kg / 62 lb
PMM-2030	200 (7.87)	300 (11.81)	259 (10.20)	59 (2.32)	23 (0.91)	26 kg / 58 lb
PMM-2040	200 (7.87)	400 (15.75)	349 (13.74)	59 (2.32)	23 (0.91)	35 kg / 77 lb
PMM-2045	200 (7.87)	450 (17.72)	409 (16.10)	59 (2.32)	23 (0.91)	40 kg / 87 lb
PMM-2050	200 (7.87)	500 (19.69)	454 (17.84)	59 (2.32)	23 (0.91)	44 kg / 97 lb
PMM-2060	200 (7.87)	600 (23.62)	559 (22.01)	59 (2.32)	23 (0.91)	53 kg / 116 lb
PMM-2530	250 (9.84)	300 (11.81)	259 (10.20)	59 (2.32)	23 (0.91)	33 kg / 73 lb
PMM-2535	250 (9.84)	350 (13.78)	304 (11.97)	59 (2.32)	23 (0.91)	38 kg / 85 lb
PMM-2540	250 (9.84)	400 (15.75)	349 (13.74)	59 (2.32)	23 (0.91)	44 kg / 97 lb
PMM-2545	250 (9.84)	450 (17.72)	409 (16.10)	59 (2.32)	23 (0.91)	49 kg / 109 lb
PMM-3040	300 (11.81)	400 (15.75)	349 (13.74)	62 (2.44)	28 (1.10)	55 kg / 122 lb
PMM-3050	300 (11.81)	500 (19.69)	459 (18.07)	62 (2.44)	28 (1.10)	69 kg / 153 lb
PMM-3060	300 (11.81)	600 (23.62)	559 (22.01)	62 (2.44)	28 (1.10)	83 kg / 183 lb
PMM-4040	400 (15.75)	400 (15.75)	349 (13.74)	62 (2.44)	28 (1.10)	94 kg / 207 lb

Unit: mm(in)

• Electro-permanent magnetic module with double sided clamping surfaces

Use:
Clamping for heavy machining for medium to large work pieces

- Features:**
- With double sided clamping surfaces
 - Can be self-clamped on the machine table
 - Top surface clamping and bottom surface clamping can be controled by different channels
 - Channel 1 for top surface clamping, Channel 2 for bottom surface clamping
 - Square pole size 70x70 mm
 - Magnetic force higher than 690 kg per pole
 - With no deformation owing to the rise of the temperature
 - No residual magnetism
 - Wokpiece larger than the table size are machinable
 - Multiple magnet combinations can provide clamping for any table size

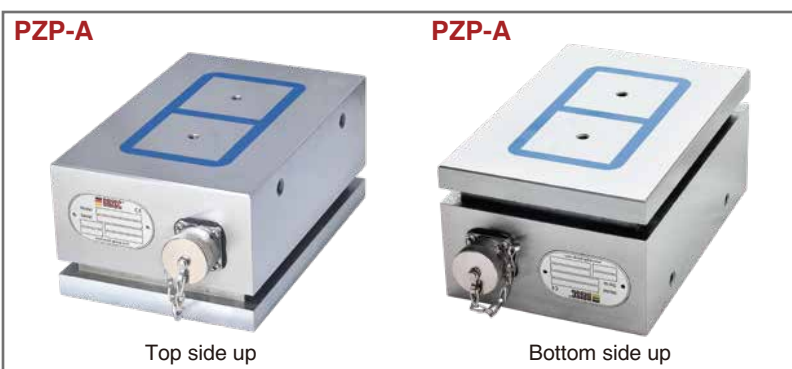
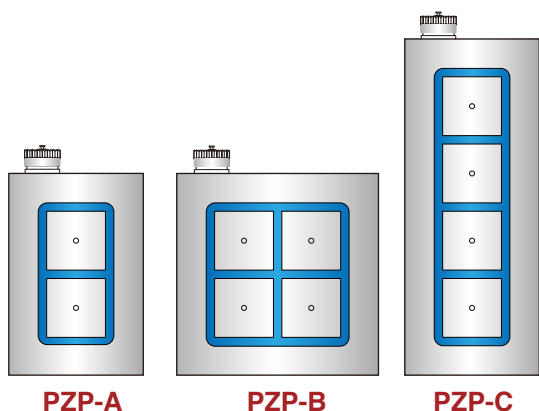

CUT-A with channel selection function
Channel 1 for top, Channel 2 for bottom



Application 1

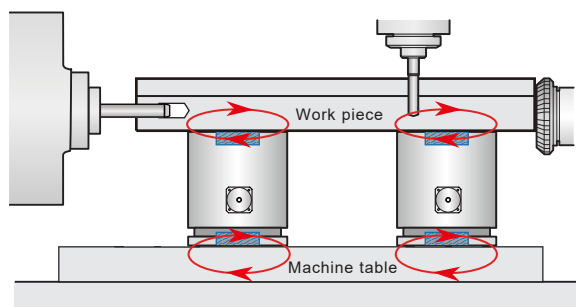

Application 2

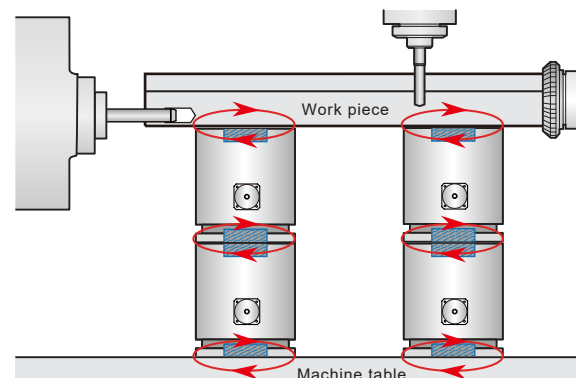

Model	Width	Length	Heigh	Pole No.	Net Weight	Control Unit (220 / 400V)	Clamping Force per side
PZP-A	160 (6.29)	240 (9.44)	110 (4.33)	2 x 2	33 kg / 62 lb	CUT-A	13.8 kN
PZP-B	240 (9.44)	240 (9.44)	110 (4.33)	4 x 2	49 kg / 62 lb	CUT-A	27.6 kN
PZP-C	160 (6.29)	400 (15.74)	110 (4.33)	4 x 2	59 kg / 62 lb	CUT-A	27.6 kN

Unit: mm(in)

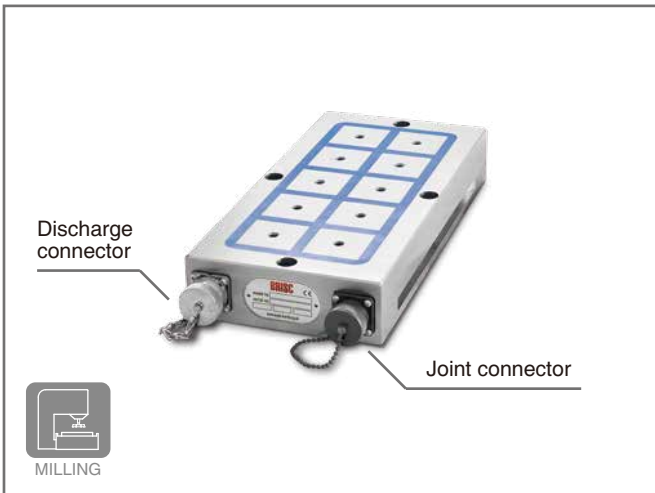

- Electro-permanent magnetic chuck

Use:
Clamping for heavy machining for medium to large work pieces

- Features:**
- Square pole size 50x50 mm
 - Magnetic force higher than 350 kg per pole
 - Electro-permanent technology with no deformation owing to the rise of the temperature
 - Distortion free clamping with auto-shim pole extensions
 - No residual magnetism
 - Controlled flux prevents magnetization of the tool
 - Workpiece larger than the table size are machinable
 - Multiple magnet combinations can provide clamping for any table size, large or small
 - Length of connection cable can be made to order

Milling

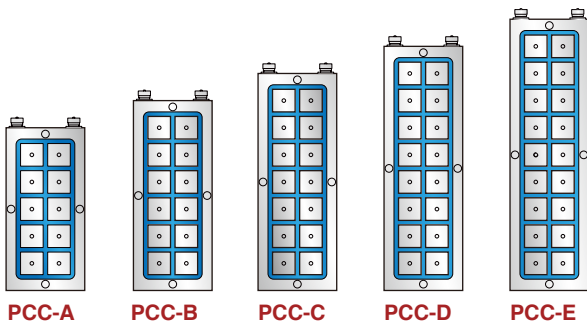

Model	Width	Length	Heigh	Pole No.	Max Plate No.	Net Weight	Control Unit (400/480V)
PCC-A	174 (6.85)	360 (14.17)	59 (2.32)	10	6	24 kg / 53 lb	CUA
PCC-B	174 (6.85)	420 (16.54)	59 (2.32)	12	6	33 kg / 73 lb	CUA
PCC-C	174 (6.85)	480 (18.90)	59 (2.32)	14	5	38 kg / 84 lb	CUA
PCC-D	174 (6.85)	540 (21.26)	59 (2.32)	16	5	43 kg / 95 lb	CUA
PCC-E	174 (6.85)	600 (23.62)	59 (2.32)	18	4	48 kg / 106 lb	CUA

Unit: mm(in)

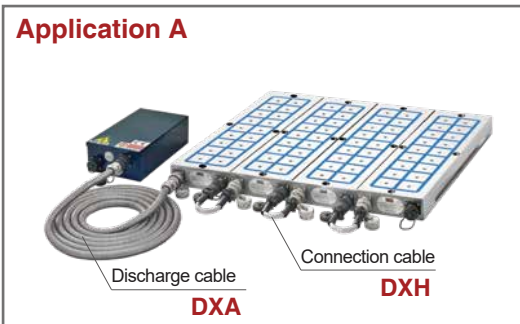

- Can be used next to each other

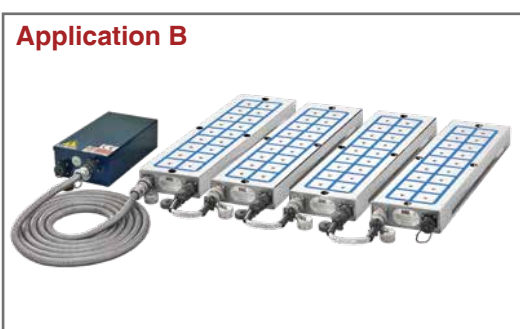
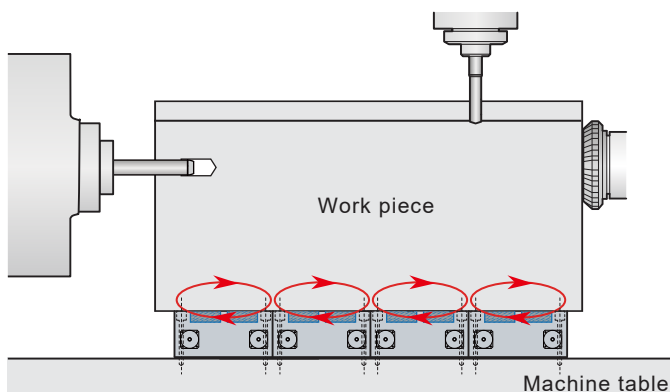

- Can be used with space in between

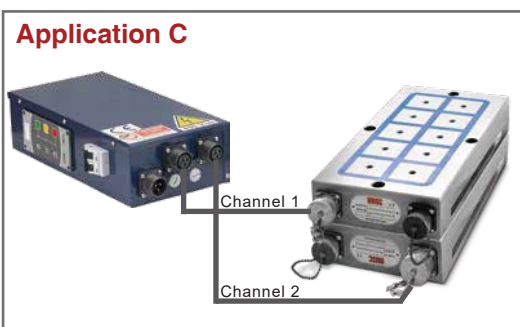
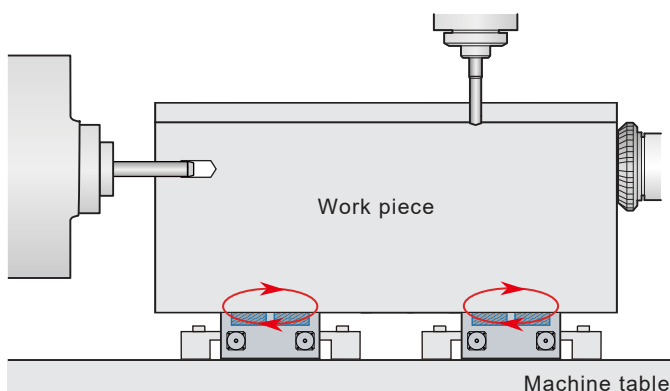

- Can bolt-together two PCC and make it two clamping surface separately

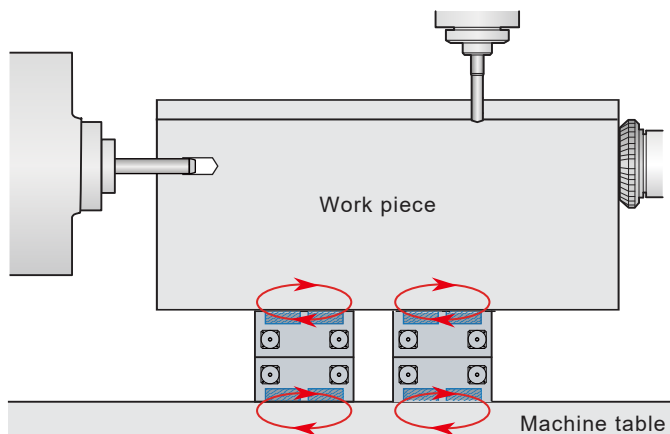

Model	Cable length	Space between chucks	Description
DXH-300	300 (11.8)	0 - 50 (0 - 1.96)	connection cable
DXH-1000	1000 (39.4)	0 - 600 (0 - 23.62)	connection cable

Unit: mm(in)

Model	Cable length	Description
DXF-1000	1000 (39.4)	extension cable
DXF-3000	3000 (118.1)	extension cable
DXA-5	5000 (196.9)	discharge cable
DXA-10	10000 (393.7)	discharge cable

Unit: mm(in)

Different length cable is available upon request.

EPK / CFT

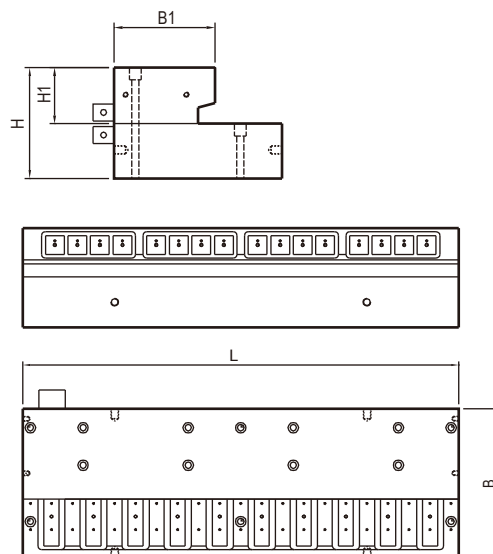

● Rail milling magnetic clamping system

Use:

Clamping for machining on rail crossings and switches

Features:

- Highest clamping force up to 180 kN/m
- No electricity needed for the system when machining
- Strong and uniform clamping, no vibrations when machining
- Quick clamping with high efficiency
- Complete machining in one set up
- Without stray magnetic fields and no magnetization of the tool
- Modules can be used jointly

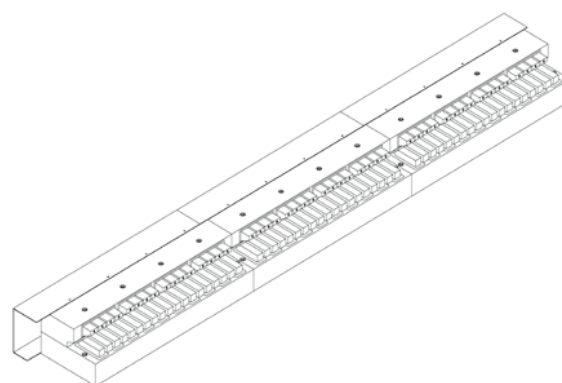

Model	Width(B)	Length(L)	Height(H)	H1	B1	Net Weight
EPK40116	400 (15.75)	1160 (45.67)	268 (10.55)	134 (5.28)	240 (9.45)	734 kg / 1616 lb

Unit: mm(in)



● Clamping force tester

Use:

For measuring the clamping force on magnetic chucks

Features:

The required pressure can be generated by turning the screw clockwise with an Allen key. The integrated pressure piston is moved far enough so that the measuring cylinder is lifted off the magnet plate when the clamping force limit is reached.

- The displayed pressure in bar corresponds to the clamping force in daN/cm². 0-25 bar corresponding to 0-25 daN/cm²
- Weight 2.0 kg
- Outer diameter 50 mm

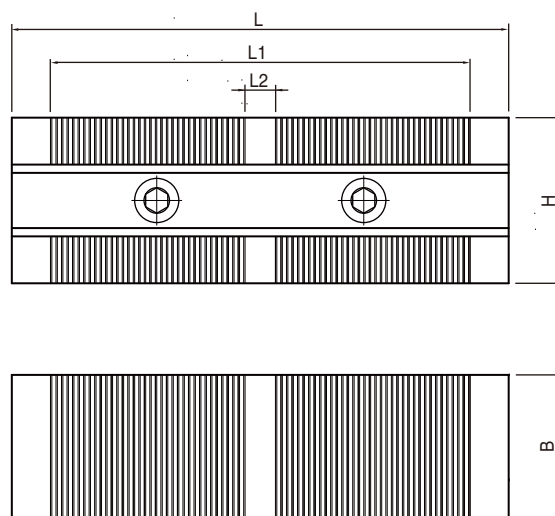

• Permanent magnetic chuck

Use:

Clamping device for holding workpieces securely on spark erosion machines (EDM) or other machining applications, or as part of a fixture.

Features:

- Two clamping surfaces on opposite and individually switchable
- PFD with pole pitch 0.5+1.5 mm
- Max. magnetic uniform clamping force up to 120 N/cm²
- Easy to activate and de-activate
- Coolant and water proof structure
- High precision and no residual magnetism
- Can be supplied in pairs

Model	Width(B)	Length(L)	Height(H)	L1	L2	P	Net Weight
PFD-0513	52 (2.05)	125 (4.92)	60 (2.36)	99 (3.90)	-	1.5+0.5	3.0 kg / 6.6 lb
PFD-0518	52 (2.05)	180 (7.09)	60 (2.36)	152.5 (6.00)	11 (0.43)	1.5+0.5	4.2 kg / 9.3 lb
PFD-0525	52 (2.05)	250 (9.84)	60 (2.36)	224.5 (8.84)	11 (0.43)	1.5+0.5	5.8 kg / 12.8 lb

Unit: mm(in)

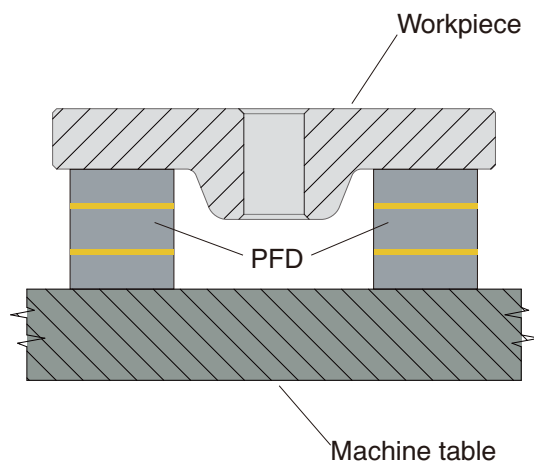

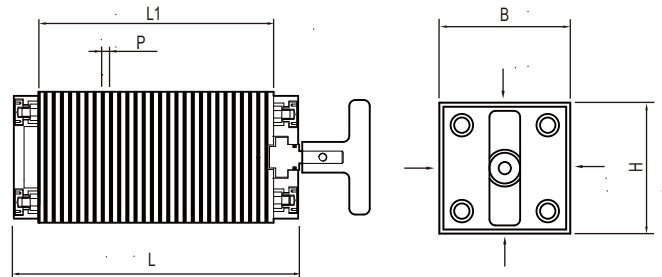

EDM

• Permanent magnetic chuck

Use:
Angular and parallel EDM of small and medium-sized workpieces

- Features:**
- Robust construction with good holding force
 - Pole pitch 2 mm bass / 2 mm steel
 - Nominal holding force standard: 50 N/cm²
 - Nominal holding force stainless 30 N/cm²
 - Magnetic field height : 2 mm
 - Polar plate re-grind of 4 mm
 - Stainless, chrome steel polar plates available for use in wire EDM



Model	Width(B)	Length(L)	Height(H)	L1	P	Net Weight
MBF-140	64 (2.52)	140 (5.51)	64 (2.52)	115 (4.53)	2+2	3.0 kg / 6.6 lb
MBF-160	64 (2.52)	160 (6.30)	64 (2.52)	135 (5.31)	2+2	4.0 kg / 8.8 lb

Unit: mm(in)

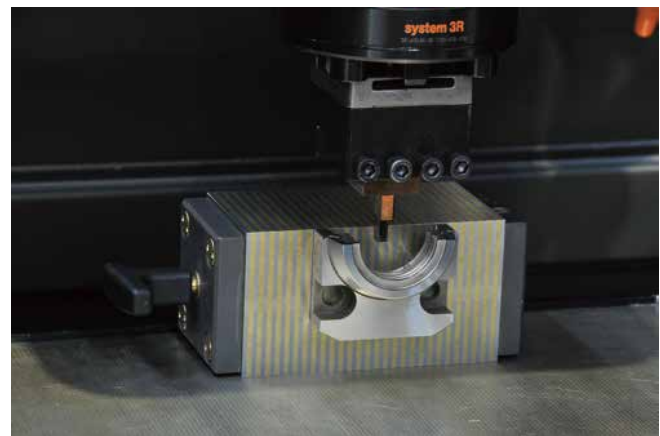

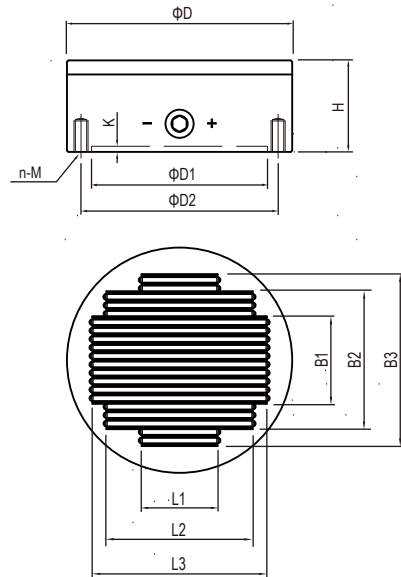

• Permanent magnetic chuck

Use:

For hard to hold parts requiring exceptionally high power, such as high alloyed tool steels and materials containing cobalt.

Features:

- Aluminium housing, pole plate made from tool steel. Extremely high clamping force through neodymium-iron-boron magnets
- Available with flange on request
- NF with pole pitch 2 + 4 mm
- Max. uniform magnetic clamping force up to 180N/cm²
- Best for small and thin workpiece
- Magnetic field height : 4 mm
- Polar plate re-grind of 3mm
- High precision with no residual magnetism

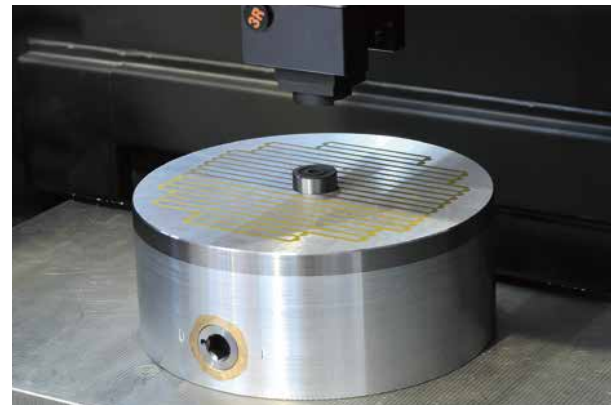

Model	Dia(D)	Height(H)	L1	L2	L3	B1	B2	B3	D1	D2	n	M	K	Net Weight
NF-100	100 (3.94)	65 (2.56)	48 (1.89)	-	-	74 (2.91)	-	-	70 (2.76)	90 (3.54)	4	6	4	2.2 kg / 4.8 lb
NF-125	125 (4.92)	65 (2.56)	54 (2.13)	88 (3.46)	-	67 (2.64)	98 (3.86)	-	95 (3.74)	110 (4.33)	4	8	4	3.4 kg / 7.5 lb
NF-160	160 (6.30)	65 (2.56)	54 (2.13)	104 (4.09)	124 (4.88)	62 (2.44)	98 (3.86)	122 (4.80)	125 (4.92)	140 (5.51)	4	10	4	5.6 kg / 12.3 lb
NF-180	180 (7.09)	65 (2.56)	64 (2.59)	104 (4.09)	124 (4.88)	62 (2.44)	98 (3.86)	134 (5.28)	125 (4.92)	160 (6.30)	4	10	4	7.1 kg / 15.6 lb
NF-200	200 (7.87)	65 (2.56)	74 (2.91)	104 (4.09)	134 (5.28)	73 (2.87)	110 (4.33)	158 (6.22)	125 (4.92)	180 (5.51)	4	10	4	8.7 kg / 19.2 lb

Unit: mm(in)

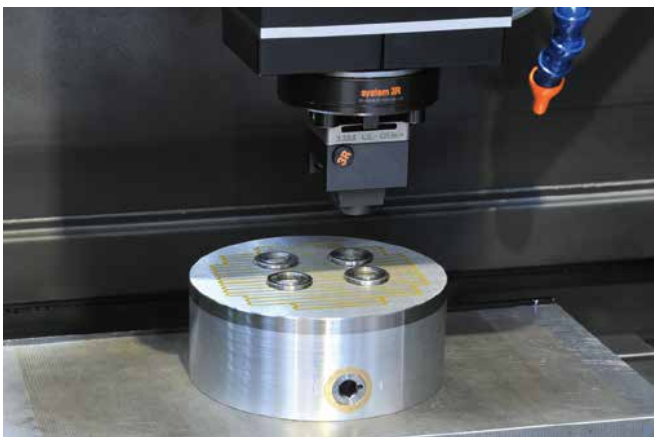

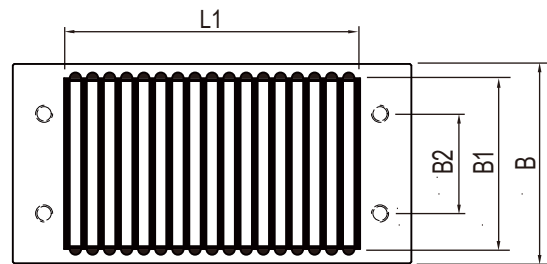
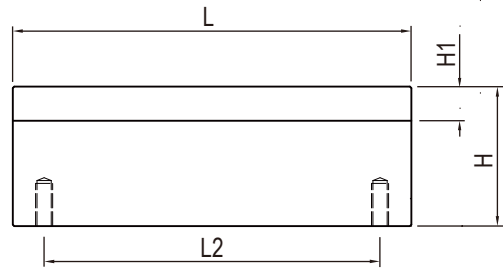

EDM

● **Permanent magnetic chuck**

Use:
For complex, small, hard to hold parts requiring extra accuracy and power

- Features:**
- PMB with pole pitch 2 + 4 mm
 - High polar plate stability of ± 0.002 mm
 - Bigger sizes available on request
 - Highest uniform clamping force up to 180 N/cm²
 - Magnetic field height : 4 mm
 - Polar plate re-grind of 3 mm
 - Clamping of more than one workpiece is possible

Model	Width(B)	Length(L)	L1	L2	Height(H)	H1	B1	B2	Net Weight
PMB-714	70 (2.76)	140 (5.51)	118 (4.65)	100 (3.94)	49 (1.93)	12 (0.47)	60 (2.36)	35 (1.38)	3.5 kg / 7.7lb
PMB-720	70 (2.76)	200 (7.87)	170 (7.00)	150 (5.91)	49 (1.93)	12 (0.47)	60 (2.36)	35 (1.38)	5 kg / 11lb

Unit: mm(in)



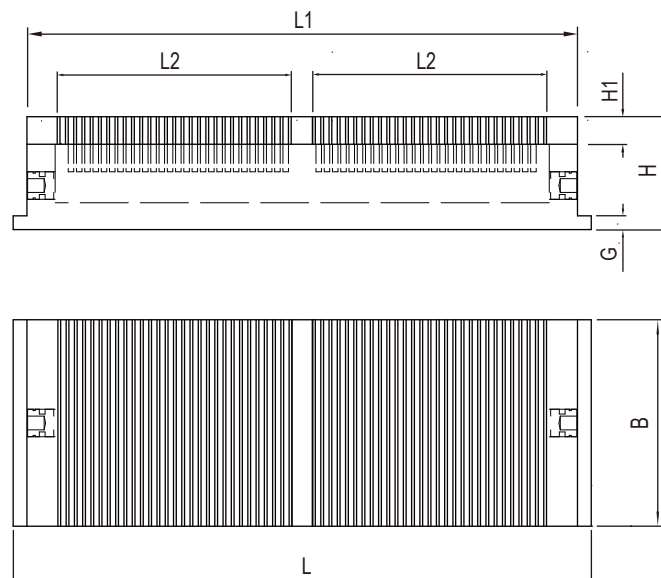

• Permanent magnetic chuck

Use:

For hard to clamp parts requiring exceptionally high power, such as high alloyed tool steels and materials containing cobalt

Features:

- Extremely high clamping force due to a specially developed construction, stable all-steel body
- ON-OFF control on both ends
- Larger models with power-operated switching mechanism available on request
- Pole pitch 4 mm ST and 2 mm with extra NdFeB between the poles
- Max. uniform magnetic clamping force up to 180 N/cm²
- Magnetic field height : 4 mm
- Polar plate re-grind of 3 mm

Model	Width(B)	Length(L)	Height(H)	L1	L2	H1	G	Net Weight
PMG-1540	150 (5.91)	420 (16.54)	82 (3.23)	400 (15.75)	170 (6.69)	20 (0.79)	10 (0.39)	33 kg / 73 lb

Unit: mm(in)

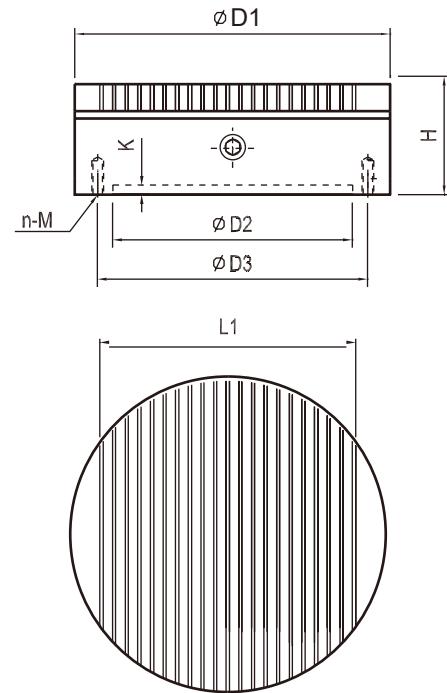

● **Circular permanent magnetic chuck with micropitch poles**

Use:

Clamping for grinding

Features:

- PMY with pole pitch 0.5+1.5 mm
- Max. uniform magnetic clamping force up to 120 N/cm²
- Best for small and thin workpiece
- Low height and light weight
- High precision with no residual magnetism

Model	Diameter(D1)	Height(H)	L1	D2	D3	n	M	K	Net Weight
PMY-100	100 (3.94)	50 (1.97)	76.5 (3.01)	60 (2.36)	85 (3.35)	4	8	4 (0.16)	3 kg / 7 lb
PMY-130	130 (5.12)	50 (1.97)	100 (3.94)	90 (3.54)	115 (4.53)	4	8	4 (0.16)	5 kg / 11 lb
PMY-150	150 (5.91)	50 (1.97)	117 (4.61)	110 (4.33)	132 (5.20)	4	8	4 (0.16)	7 kg / 15 lb
PMY-160	160 (6.30)	57 (2.24)	129 (5.08)	120 (4.72)	140 (5.51)	4	10	4 (0.16)	8.9 kg / 20 lb
PMY-200	200 (7.87)	57 (2.24)	169 (6.65)	160 (6.30)	180 (7.09)	4	10	4 (0.16)	14 kg / 31 lb
PMY-250	250 (9.84)	57 (2.24)	213 (8.39)	200 (7.87)	230 (9.06)	4	10	4 (0.16)	21.9 kg / 48 lb
PMY-300	300 (11.81)	62 (2.44)	265 (10.43)	250 (9.84)	280 (11.02)	4	12	4 (0.16)	34 kg / 76 lb
PMY-400	400 (15.75)	67 (2.64)	360 (14.17)	320 (12.60)	360 (14.17)	6	12	4 (0.16)	66 kg / 145 lb
PMY-500	500 (19.69)	67 (2.64)	450 (17.72)	420 (16.54)	460 (18.11)	6	12	5 (0.20)	103 kg / 227 lb
PMY-600	600 (23.62)	67 (2.64)	553 (21.77)	500 (19.69)	540 (21.26)	6	12	5 (0.20)	149 kg / 327 lb

Unit: mm(in)

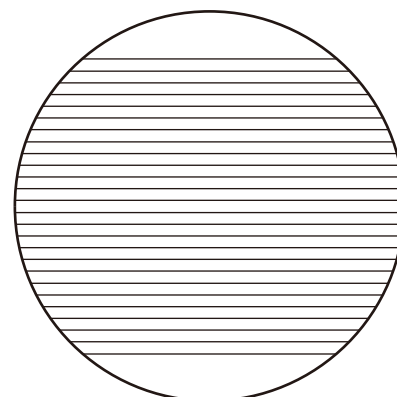
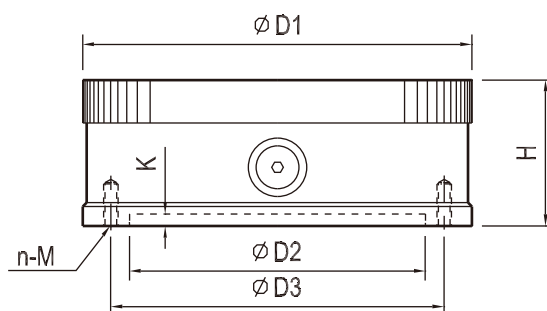

• Circular permanent magnetic chuck with parallel poles

Use:

Clamping for grinding and turning

Features:

- Pole pitch 5+8 mm
- Max. magnetic clamping force up to 140 N/cm²
- Concentric grooves simplify the centring of workpiece
- Variable magnetic clamping force
- Balanced for high RPM
- Centre drilling of locating hole is available on request
- High precision with no residual magnetism

Model	Diameter(D1)	Height(H)	D2	D3	n	M	K	Net Weight
NY-100	100 (3.94)	60 (2.36)	60 (2.36)	85 (3.35)	4	8	5 (0.2)	3.6 kg / 7.92 lb
NY-130	130 (5.12)	60 (2.36)	90 (3.54)	115 (4.53)	4	8	5 (0.2)	6.2 kg / 13.6 lb
NY-150	150 (5.91)	60 (2.36)	110 (4.33)	132 (5.20)	4	8	5 (0.2)	8.3 kg / 18.3 lb
NY-160	160 (6.30)	60 (2.36)	120 (4.72)	140 (5.51)	4	8	5 (0.2)	9.4 kg / 20.7 lb
NY-200	200 (7.87)	60 (2.36)	150 (6.30)	180 (7.09)	4	8	5 (0.2)	14.5 kg / 31.9 lb
NY-250	250 (9.84)	60 (2.36)	200 (7.87)	230 (9.06)	4	10	5 (0.2)	23 kg / 50.6 lb
NY-300	300 (11.81)	65 (2.56)	250 (9.84)	280 (11.02)	4	10	5 (0.2)	36 kg / 79.2 lb
NY-350	350 (13.78)	65 (2.56)	250 (9.84)	330 (12.99)	6	12	5 (0.2)	49 kg / 107.8 lb
NY-400	400 (15.75)	67 (2.64)	320 (12.60)	360 (14.17)	6	12	5 (0.2)	66 kg / 145.2 lb
NY-450	450 (17.72)	67 (2.64)	350 (13.78)	400 (15.74)	6	12	5 (0.2)	83.5 kg / 183.7 lb
NY-500	500 (19.69)	67 (2.64)	400 (15.75)	450 (17.72)	6	12	5 (0.2)	103 kg / 226.6 lb

Unit: mm(in)

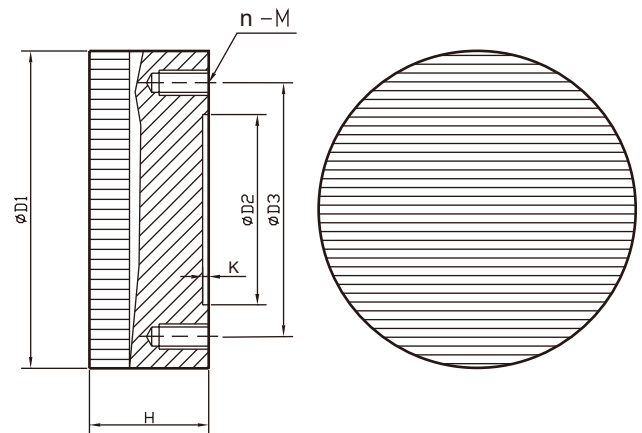

● **Circular electro-permanent magnetic**

Use:

Clamping for grinding of disc shaped workpieces on internal and external grinders with rotary tables

Features:

- Pole pitch 1+3 mm
- Max. magnetic clamping force up to 120 N/cm²
- Electro-permanent technology with no deformation owing to the rise of temperature
- Can eliminate residual magnetism from the workpiece
- Coolant and water proof structure
- Mono-block housing for maximum stability

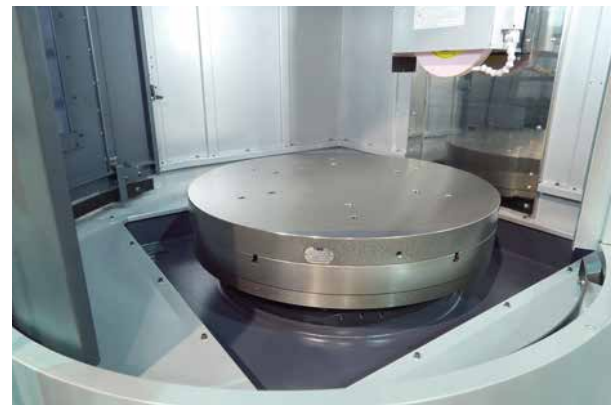

Model	Diameter(D1)	Height(H)	D2	D3	n	M	K	Net Weight	Controller (400V)
EPY-300	300(11.81)	75(2.95)	160(6.30)	190(7.48)	4	10	4 (0.16)	40 kg / 88 lb	CGA
EPY-400	400(11.75)	75(2.95)	210(7.87)	250(9.84)	6	12	4 (0.16)	73 kg / 161 lb	CGA
EPY-500	500(19.69)	75(2.95)	320(12.60)	380(14.96)	6	12	4 (0.16)	115 kg / 254 lb	CGA
EPY-600	600(23.62)	75(2.95)	350(13.78)	390(15.35)	6	12	4 (0.16)	165 kg / 364 lb	CGA
EPY-700	700(27.56)	75(2.95)	400(15.75)	450(17.72)	6	16	4 (0.16)	265 kg / 584 lb	CGD
EPY-800	800(31.50)	75(2.95)	450(17.72)	500(19.69)	6	16	4 (0.16)	295 kg / 650 lb	CGD
EPY-1000	1000(39.37)	75(2.95)	550(21.65)	620(24.41)	8	16	4 (0.16)	460 kg / 1014 lb	CGD
EPY-1200	1200(47.24)	80 (3.15)	Upon request					590 kg / 1298 lb	CGF
EPY-1500	1500(59.06)	80 (3.15)						922 kg / 2028 lb	CGF

Unit: mm(in)

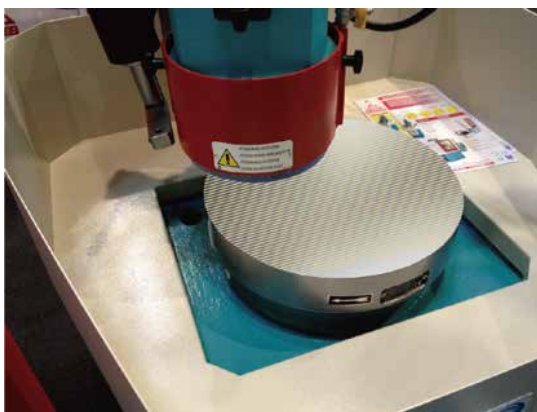

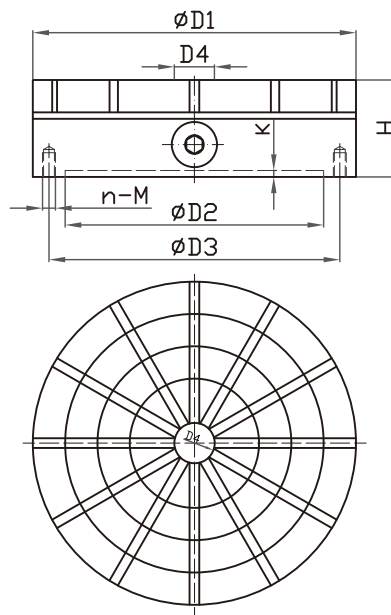

● **Circular permanent magnetic chuck with radial poles**

Use:

Clamping for grinding and turning of ring-shaped workpieces

Features:

- Max. magnetic clamping force up to 180 N/cm²
- Concentric grooves simplify the centring of workpiece
- Centre through hole is available on request for workpiece
- T-slots available on request for pole extensions allowing 3 sided access in single set-up



Model	Diameter(D1)	Height(H)	D2	D3	D4	n	M	K	Net Weight
NR-100	100 (3.94)	60 (2.36)	60 (2.36)	85 (3.35)	16 (0.63)	4	6	4 (0.16)	3.3 kg / 7.26 lb
NR-130	130 (5.12)	60 (2.36)	50 (1.97)	100 (3.94)	20 (0.79)	4	6	4 (0.16)	6 kg / 13 lb
NR-150	150 (5.91)	60 (2.36)	90 (3.54)	115 (4.53)	20 (0.79)	4	8	4 (0.16)	8 kg / 18 lb
NR-160	160 (6.30)	60 (2.36)	120 (4.72)	140 (5.51)	20 (0.79)	4	8	4 (0.16)	10 kg / 22 lb
NR-200	200 (7.87)	60 (2.36)	160 (6.30)	180 (7.09)	28 (1.10)	4	8	4 (0.16)	14 kg / 31 lb
NR-250	250 (9.84)	60 (2.36)	200 (7.87)	230 (9.06)	32 (1.26)	4	10	4 (0.16)	23 kg / 51 lb
NR-300	300 (11.81)	80 (3.15)	250 (9.84)	270 (10.63)	40 (1.57)	7	12	4 (0.16)	43 kg / 95 lb
NR-320	320 (12.60)	80 (3.15)	250 (9.84)	270 (10.63)	40 (1.57)	6	12	4 (0.16)	50 kg / 110 lb
NR-350	350 (13.78)	80 (3.15)	250 (9.84)	280 (11.02)	40 (1.57)	6	12	4 (0.16)	59 kg / 130 lb
NR-400	400 (15.75)	80 (3.15)	200 (7.87)	260 (10.24) / 340 (13.39)	55 (2.17)	12	10	6 (1.81)	78 kg / 172 lb
NR-500	500 (19.69)	95 (3.74)	200 (7.87)	300 (11.81) / 400 (15.75)	60 (2.36)	12	10	8 (0.31)	146 kg / 321 lb
NR-600	600 (23.62)	95 (3.74)	250 (9.84)	350 (13.78) / 450 (17.72)	90 (3.54)	12	10	8 (0.31)	210 kg / 462 lb

Unit: mm(in)

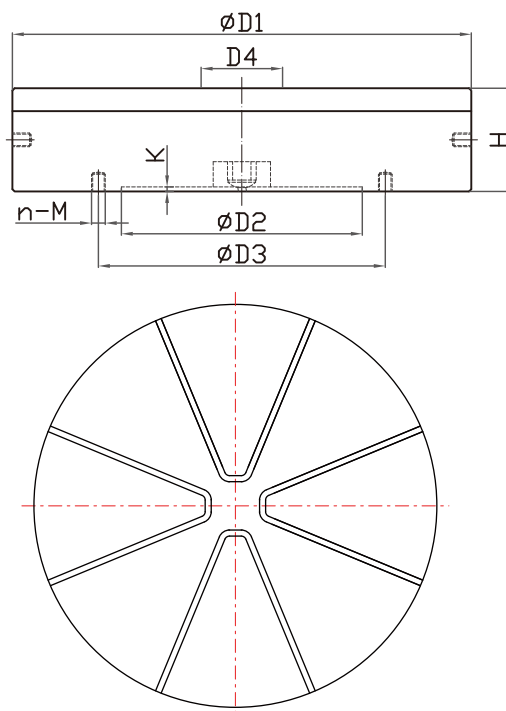
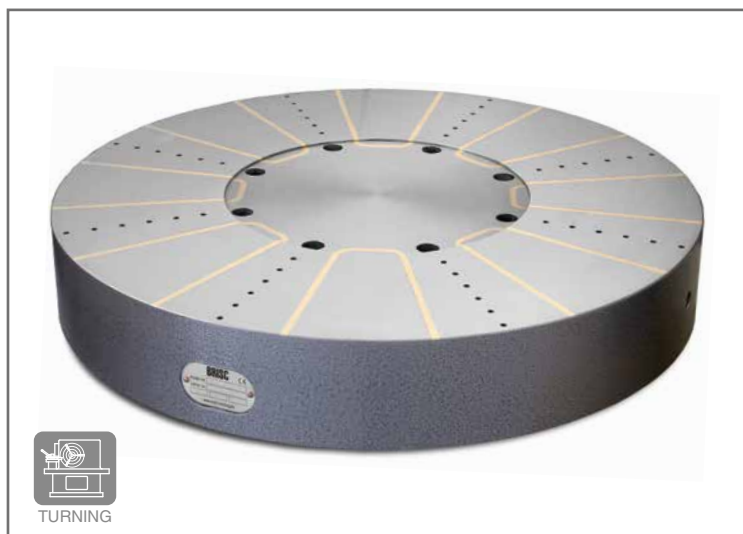

Turning / Grinding

• Circular electromagnetic chuck with radial poles

Use:

Clamping for grinding of ring shaped work pieces

Features:

- Highest clamping force up to 160 N/cm²
- T-slot can be available as an option with pole extension for grinding wheel at three side operation
- Magnetic force cover the edge
- Real magnetic poles
- Coolant and water proof structure
- Minimum mechanical deformation with solid one-piece housing

Model	Diameter(D1)	Height(H)	D2	D3	D4	K	n	M	Voltage	Current	Net Weight
EMW-400	400 (15.75)	90 (3.54)	210 (8.27)	250 (9.84)	60 (2.36)	4 (0.16)	6	12	DC 110 V	1.4 A	76 kg / 167 lb
EMW-500	500 (19.69)	90 (3.54)	280 (11.02)	320 (12.60)	80 (3.15)	4 (0.16)	6	12	DC 110 V	1.8 A	120 kg / 264 lb
EMW-600	600 (23.62)	100 (3.94)	350 (13.78)	390 (15.35)	80 (3.15)	4 (0.16)	6	12	DC 110 V	2.5 A	195 kg / 429 lb
EMW-700	700 (27.56)	100 (3.94)	400 (15.75)	450 (17.72)	110 (4.33)	4 (0.16)	6	16	DC 110 V	3.2 A	265 kg / 583 lb
EMW-800	800 (31.50)	100 (3.94)	450 (17.72)	500 (19.69)	140 (5.51)	4 (0.16)	6	16	DC 110 V	4.0 A	365 kg / 803 lb
EMW-900	900 (35.43)	100 (3.94)	500 (21.65)	550 (23.62)	200 (7.87)	4 (0.16)	8	16	DC 110 V	5.0 A	474 kg / 1043 lb
EMW-1000	1000 (39.37)	100 (3.94)	550 (21.65)	600 (23.62)	260 (10.24)	4 (0.16)	8	16	DC 110 V	6.0 A	550 kg / 1210 lb
EMW-1250	1250 (49.21)	125 (4.92)							DC 110 V	8.8 A	1143 kg / 2515 lb
EMW-1350	1350 (53.15)	125 (4.92)							DC 110 V	10.0 A	1334 kg / 2934 lb
EMW-1500	1500 (59.06)	125 (4.92)							DC 110 V	13.1 A	1646 kg / 3622 lb
EMW-1600	1600 (62.99)	125 (4.92)							DC 110 V	14.8 A	1873 kg / 4121 lb
EMW-1800	1800 (70.87)	125 (4.92)							DC 110 V	16.0 A	2371 kg / 5216 lb

Upon request

Unit: mm(in)

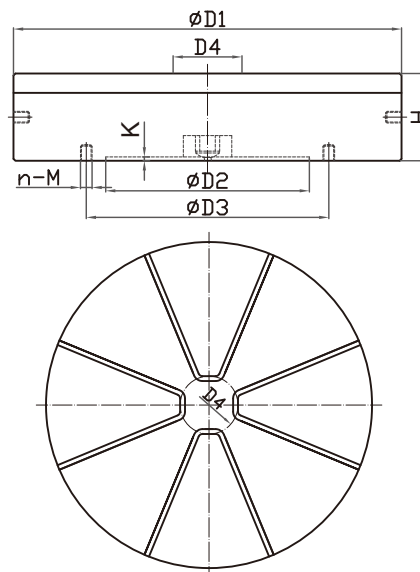

• Circular electro-permanent magnetic chuck with radial poles

Use:

Clamping for turning or grinding of ring shaped workpieces

Features:

- Max. magnetic clamping force up to 160 N/cm²
- Electro-permanent technology with no deformation owing to the rise of temperature
- Can eliminate the residual magnetism from the workpiece
- T-slot available on request for pole extensions allowing 3 sided access in single set-up
- Mono-block housing for maximum stability



Model	Size (D1)	Height (H)	D2	D3	D4	n	M	K	Pole No.	Net weight	Controller (400V)
EPW-G/S	400 (11.75)	115 (4.53)	200 (7.87)	280 (11.02)	80 (3.15)	6	12	4 (0.16)	12	107 kg / 236 lb	CGA
EPW-G/S	500 (19.68)	120 (4.72)	280 (11.02)	320 (12.6)	100 (3.94)	6	12	4 (0.16)	14	158 kg / 348 lb	CGA
EPW-G/S	600 (23.62)	120 (4.72)	350 (13.78)	390 (15.35)	150 (5.91)	8	12	4 (0.16)	16	227 kg / 499 lb	CGA
EPW-G/S	700 (27.56)	120 (4.72)	400 (15.75)	450 (17.72)	150 (5.91)	8	16	4 (0.16)	16	310 kg / 682 lb	CGA
EPW-G/S	800 (31.50)	120 (4.72)	450 (17.72)	500 (19.69)	160 (6.30)	8	16	4 (0.16)	16	404 kg / 889 lb	CGA
EPW-G/S	1000 (39.37)	120 (4.72)	550 (21.65)	620 (24.41)	260 (10.24)	8	16	4 (0.16)	24	632 kg / 1391 lb	CGD
EPW-G/S	1250 (49.21)	125 (4.92)								1076 kg / 2367 lb	
EPW-G/S	1600 (62.99)	125 (4.92)								1763 kg / 3879 lb	Upon request
EPW-G/S	1800 (70.87)	125 (4.92)								2232 kg / 4910 lb	
EPW-G/S	2000 (78.74)	125 (4.92)								2755 kg / 6061 lb	

Upon request

Unit: mm(in)



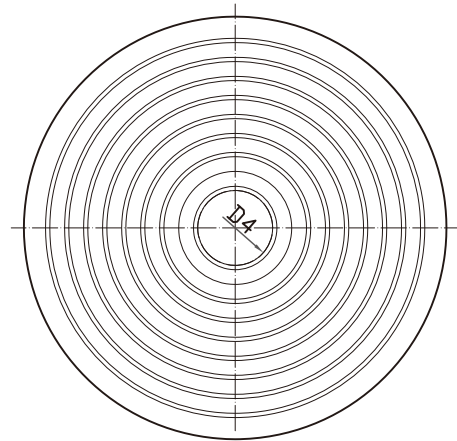
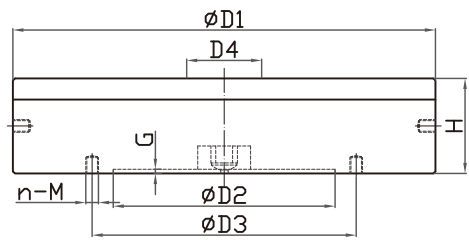

Turning

• Circular electromagnetic chuck with concentric poles

Use:

Clamping for grinding of disc shaped workpieces

Features:

- Pole pitch 4+12 mm
- Highest uniform clamping force up to 120 N/cm²
- Gap free construction pole plate
- Real magnetic poles
- Coolant and water proof structure
- Minimum mechanical deformation with solid one-piece housing

Model	Diameter(D1)	Height(H)	D2	D3	D4	K	n	M	Voltage	Current	Net Weight
EMY-300	300 (11.81)	90 (3.54)	160 (6.30)	190 (7.48)	80 (3.15)	3 (0.12)	4	12	DC 110 V	0.82 A	45 kg / 99 lb
EMY-400	400 (15.75)	105 (4.13)	210 (8.27)	250 (9.84)	100 (3.94)	4 (0.16)	6	12	DC 110 V	1.36 A	92 kg / 202 lb
EMY-500	500 (19.69)	105 (4.13)	280 (11.02)	320 (12.60)	150 (5.91)	4 (0.16)	6	12	DC 110 V	1.73 A	144 kg / 317 lb
EMY-600	600 (23.62)	115 (4.53)	350 (13.78)	390 (15.35)	150 (5.91)	4 (0.16)	6	16	DC 110 V	3.50 A	229 kg / 504 lb
EMY-700	700 (27.56)	120 (4.72)	400 (15.75)	450 (17.72)	160 (6.30)	4 (0.16)	6	16	DC 110 V	4.00 A	326 kg / 717 lb
EMY-800	800 (31.50)	120 (4.72)	450 (17.72)	500 (19.69)	200 (7.87)	4 (0.16)	6	16	DC 110 V	4.50 A	426 kg / 937 lb
EMY-900	900 (35.43)	120 (4.72)	550 (21.65)	600 (23.62)	260 (10.24)	4 (0.16)	6	16	DC 110 V	5.50 A	539 kg / 1186 lb
EMY-1000	1000 (39.37)	120 (4.72)	550 (21.65)	620 (24.41)	300 (11.81)	4 (0.16)	8	16	DC 110 V	6.00 A	665 kg / 1463 lb
EMY-1100	1100 (43.31)	125 (4.92)							DC 110 V	7.50 A	839 kg / 1677 lb
EMY-1200	1200 (47.24)	125 (4.92)							DC 110 V	8.73 A	998 kg / 2200 lb
EMY-1300	1300 (51.18)	125 (4.92)							DC 110 V	10.00 A	1171 kg / 2576 lb
EMY-1400	1400 (55.12)	125 (4.92)							DC 110 V	12.00 A	1358 kg / 2987 lb
EMY-1500	1500 (59.06)	125 (4.92)							DC 110 V	13.09 A	1545 kg / 3399 lb
EMY-1600	1600 (62.99)	125 (4.92)							DC 110 V	14.82 A	1760 kg / 3872 lb

Upon request

Unit: mm(in)

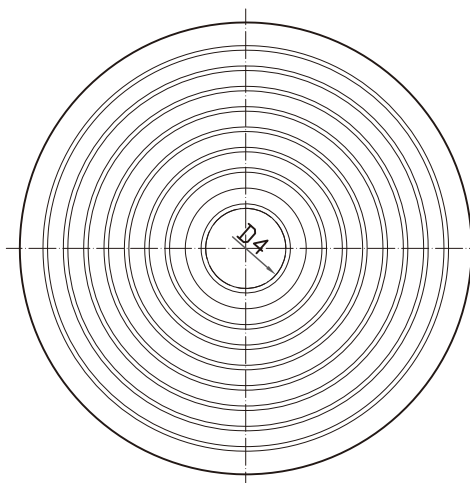
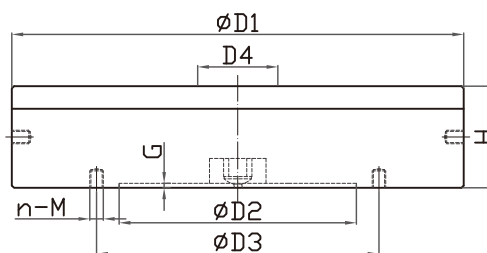

● Circular electro-permanent magnetic chuck with concentric poles

Use:

Clamping for grinding of disc shaped workpieces

Features:

- Pole pitch 4+12 mm
- Highest uniform clamping force up to 120 N/cm²
- Electro-permanent technology with no deformation owing to the rise of the temperature
- Gap free construction pole plate
- Real magnetic poles
- Coolant and water proof structure
- Minimum mechanical deformation with solid one-piece housing

Model	Diameter (D1)	Height (H)	D2	D3	D4	K	n	M	Net Weight	Controller (400V)
EPQ-400	400 (15.75)	100 (3.94)	210 (8.27)	250 (9.84)	150 (5.91)	4 (0.16)	6	12	85 kg / 187 lb	CGA
EPQ-500	500 (19.69)	100 (3.94)	280 (11.02)	320 (12.60)	150 (5.91)	4 (0.16)	6	12	135 kg / 298 lb	CGA
EPQ-600	600 (23.62)	100 (3.94)	350 (13.78)	390 (15.35)	150 (5.91)	4 (0.16)	6	12	195 kg / 430 lb	CGA
EPQ-700	700 (27.56)	100 (3.94)	400 (15.75)	450 (17.72)	200 (7.87)	4 (0.16)	6	16	265 kg / 584 lb	CGA
EPQ-800	800 (31.50)	100 (3.94)	450 (17.72)	500 (19.69)	200 (7.87)	4 (0.16)	6	16	365 kg / 805 lb	CGD
EPQ-900	900 (27.56)	100 (3.94)	500 (19.69)	560 (22.05)	300 (11.81)	4 (0.16)	8	16	440 kg / 970 lb	CGD
EPQ-1000	1000 (39.37)	100 (3.94)	550 (21.65)	620 (24.41)	300 (11.81)	4 (0.16)	8	16	550 kg / 1213 lb	CGD
EPQ-1100	1100 (43.31)	125 (4.92)							830 kg / 1830 lb	CGD
EPQ-1200	1200 (47.24)	125 (4.92)							990 kg / 2183 lb	CGF
EPQ-1300	1300 (51.18)	125 (4.92)							1160 kg / 2557 lb	CGF
EPQ-1400	1400 (55.12)	125 (4.92)							1350 kg / 2976 lb	CGF
EPQ-1500	1500 (59.06)	125 (4.92)							1550 kg / 3417 lb	CGF
EPQ-1600	1600 (62.99)	125 (4.92)							1760 kg / 3880 lb	CGF

Upon request

Unit: mm(in)

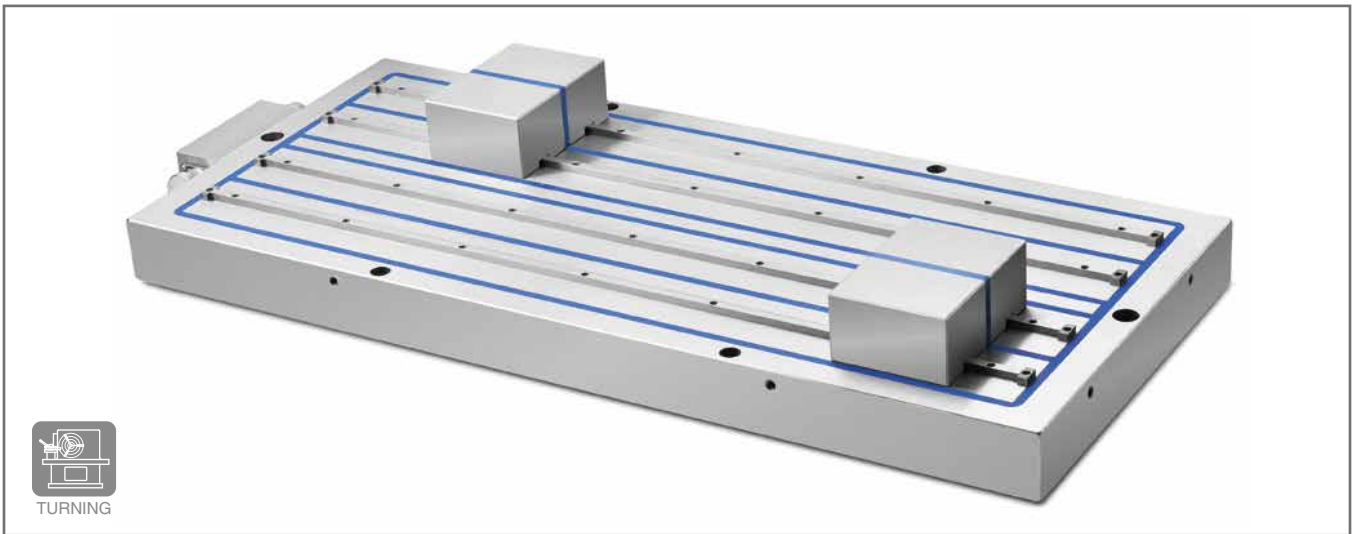

● **Electro-permanent magnetic chuck for heavy turning**

Use:
Universal clamping for heavy turning

- Features:**
- Sliding pole extension
 - Max. magnetic clamping force up to 180 N/cm²
 - Highly concentrated magnetic field with low flux depth
 - Prevents magnetization of tooling
 - Coolant proof structure
 - Easy to deploy
 - High precision with no residual magnetism
 - Easy and economic to use with different modules combination

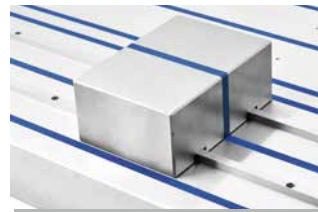
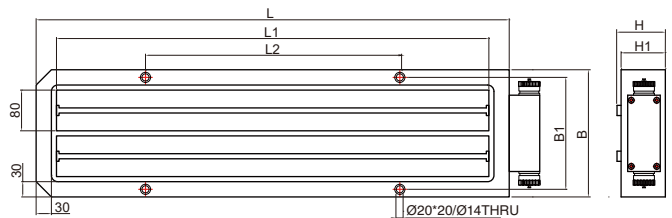

■ Sliding pole extensions

Model	Width(B)	Length(L)	L1	L2	B1	Height(H)	H	Net weight
PR80-2545	250 (9.8)	450 (17.7)	370 (14.6)	350 (13.8)	220 (8.7)	80 (3.1)	87 (3.4)	73 kg / 160 lb
PR80-25100	250 (9.8)	930 (36.6)	850 (33.5)	500 (19.7)	220 (8.7)	80 (3.1)	87 (3.4)	160 kg / 352 lb
PR80-46100	460 (18.1)	1040 (40.9)	950 (37.4)	500 (19.7)	430(16.9)	80 (3.1)	87 (3.4)	228 kg / 502 lb

Unit: mm(in)

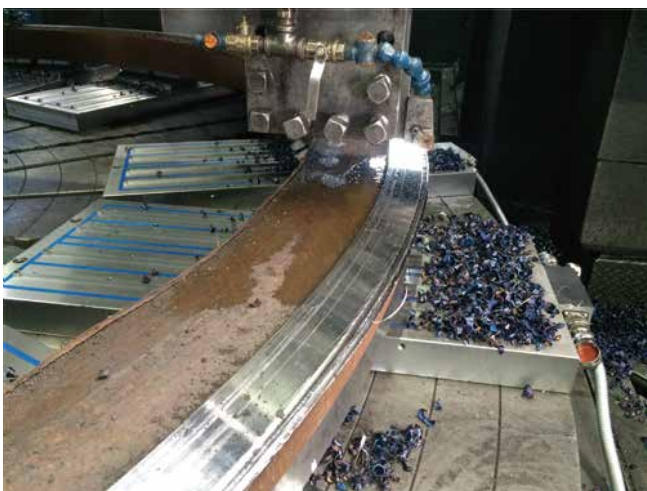

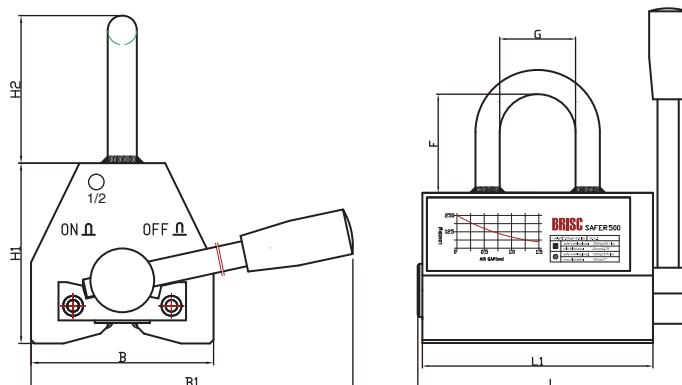

• Permanent lifting magnet

Use:

For lifting ferromagnetic material with patented test position for safer lifting

Features:

- compact and light
- maximum 3 times breakaway force
- suitable for flat and round material
- maintenance free design
- safety device prevent accidental deactivation
- can be switched off by one hand only



Model	Safe Working Load	B	B1	L	L1	H1	H2	F	G	Net Weight
SAFER-150	150 kg/330 lb	60 (2.36)	162 (6.38)	114 (4.49)	93 (3.66)	69 (2.72)	50 (1.97)	40 (1.57)	30 (1.18)	4 kg/8.8 lb
SAFER-300	300 kg/660 lb	100 (3.94)	230 (9.06)	178 (7)	152 (5.98)	99 (3.9)	81 (3.19)	65 (2.56)	50 (1.97)	8 kg/17.6 lb
SAFER-600	600 kg/1320 lb	120 (4.72)	230 (9.06)	273 (10.75)	256 (10.08)	99 (3.9)	81 (3.19)	65 (2.56)	50 (1.97)	19 kg/41.8 lb
SAFER-1200	1200 kg/2640 lb	146 (5.75)	315 (12.4)	334 (13.15)	316 (12.44)	125 (4.92)	112 (4.41)	92 (3.62)	64 (2.52)	40 kg/88 lb
SAFER-2000	2000 kg/4400 lb	165 (6.5)	510 (20.08)	516 (20.31)	484 (19.06)	165 (6.5)	112 (4.41)	92 (3.62)	64 (2.52)	85 kg/187 lb
SAFER-3000	3000 kg/6600 lb	200 (7.87)	610 (24.02)	596 (23.46)	550 (21.65)	217 (8.54)	125 (4.92)	100 (3.94)	70 (2.76)	150 kg/330 lb
SAFER-5000	5000 kg/11000 lb	310 (12.20)	930 (36.61)	748 (29.45)	706 (27.80)	284 (11.18)	160 (6.3)	130 (5.12)	100 (3.94)	430 kg/946 lb

Model	Load Plate Max	Plate Min Thickness	Plate Max Length	Load Round Max	Round Min Thickness	Round Max Dia.
SAFER-150	150 kg/330 lb	15 (0.59)	1000 (39.37)	60 kg/132 lb	10 (0.39)	150 (5.9)
SAFER-300	300 kg/660 lb	20 (0.79)	1500 (59.06)	120 kg/264 lb	10 (0.39)	180 (7.09)
SAFER-600	600 kg/1320 lb	25 (0.98)	2000 (78.74)	240 kg/528 lb	15 (0.59)	250 (9.84)
SAFER-1200	1200 kg/2640 lb	40 (1.57)	3000 (118.11)	480 kg/1056 lb	25 (0.98)	280 (11.02)
SAFER-2000	2000 kg/4400 lb	55 (2.17)	3000 (118.11)	800 kg/1760 lb	35 (1.38)	350 (13.78)
SAFER-3000	3000 kg/6600 lb	70 (2.76)	3500 (137.8)	1200 kg/2640 lb	45 (1.77)	400 (15.75)
SAFER-5000	5000 kg/11000 lb	85 (3.35)	4000 (157.48)	2000 kg/4400 lb	55 (2.17)	450 (17.7)

Unit: mm(in)

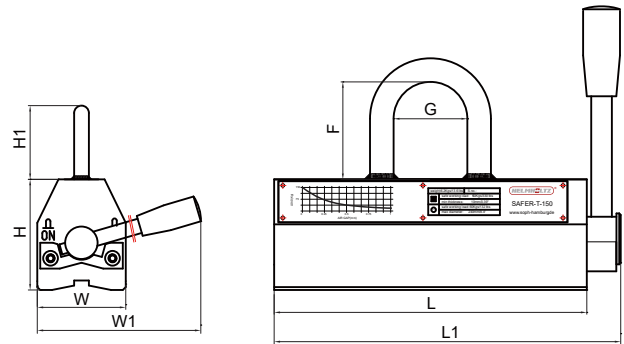

Lifting magnets

• Permanent lifting magnet for safe handling of thin plates

Use:
 Plate handling for thin plates
 De-stack down to 10 mm plates

- Features:**
- Special design allows controlled depth of flux
 - High power with shallow flux depth, Specifically designed for de-stacking thin plates
 - High capacity with low flux depth



Model	Width(W)	Length(L)	Height(H)	H1	W1	L1	G	F	Net Weight
SAFER-T-150	60 (2.36)	205 (8.07)	75 (2.95)	50 (1.97)	162 (6.38)	223 (8.78)	30 (1.18)	40 (1.57)	6.2 kg / 24 lb
SAFER-T-250	100 (3.94)	230 (9.06)	108 (4.25)	81 (3.19)	230 (9.06)	258 (10.16)	50 (1.97)	65 (2.56)	13 kg / 62 lb

Model	Flat load Max	Min Thickness	Max Length	Load Round Max	Round Min Diameter	Round Max Dia.
SAFER-T-150	150 kg/330 lb	10 (0.39)	1200 (47.24)	60 kg/132 lb	60 (2.36)	180 (7.09)
SAFER-T-250	250 kg/550 lb	12 (0.47)	1500 (59.06)	100 kg/220 lb	60 (2.36)	180 (7.09)

Unit: mm(in)

SAFER-R

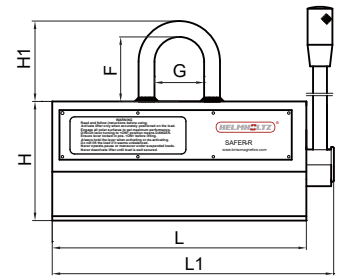
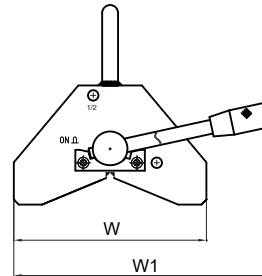

- **Permanent lifting magnet for safe handling of round work piece**

Use:

Round or flat, the “safest” way to handle a load.

Features:

- Larger V shape pole shoes than standard PLM to ensure safer conditions
- Higher performance on rounds than standard PLM
- Larger V for higher stability on round stock
- Low flux depth allowing de-stacking of thin loads



Model	Width(W)	Length(L)	Height(H)	H1	W1	L1	G	F	Net Weight
SAFER-R-300	123 (4.84)	152 (5.98)	108 (4.25)	81 (3.19)	230 (9.06)	178 (7.01)	50 (1.97)	65 (2.56)	11 kg / 24 lb
SAFER-R-600	194 (7.64)	256 (10.08)	120 (4.72)	81 (3.19)	260 (10.24)	284 (11.18)	50 (1.97)	65 (2.56)	28 kg / 62 lb
SAFER-R-1200	370 (14.57)	298 (11.73)	240 (9.45)	112 (4.41)	615 (24.12)	335 (1.38)	64 (2.52)	92 (3.62)	123 kg / 270 lb
SAFER-R-2000	370 (14.57)	484 (19.06)	240 (9.45)	112 (4.41)	615 (24.12)	521 (20.51)	100 (3.94)	130 (5.12)	200 kg / 440 lb
SAFER-R-3000	440 (17.32)	550 (21.65)	285 (11.22)	160 (6.30)	730 (28.74)	596 (23.46)	70 (2.76)	100 (3.94)	350 kg / 770 lb

Model	Flat load Max	Min Thickness	Max Length	Load Round Max	Round Min Diameter	Round Max Diameter
SAFER-R-300	300 kg/660 lb	20 (0.79)	1500 (59.06)	150 kg/330 lb	60 (2.36)	200 (7.87)
SAFER-R-600	600 kg/1320 lb	25 (0.98)	2000 (78.74)	300 kg/660 lb	60 (2.36)	305 (12.00)
SAFER-R-1200	1000 kg/2200 lb	40 (1.57)	3000 (118.11)	500 kg/1100 lb	80 (3.15)	360 (14.17)
SAFER-R-2000	2000 kg/4400 lb	55 (2.17)	3000 (118.11)	1000 kg/2200 lb	80 (3.15)	460 (18.11)
SAFER-R-3000	3000 kg/6600 lb	70 (2.76)	3500 (137.8)	1500 kg/3300 lb	100 (3.94)	560 (22.05)

BLM / PRA

BLM

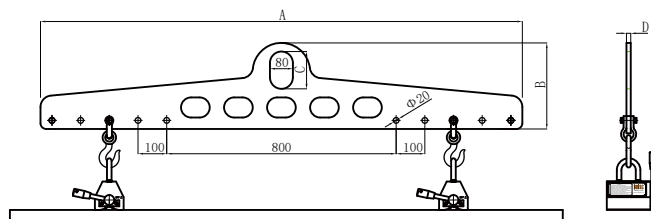

• BLM- SAFER Fixed Beam

Features:

■ The BLM spreader beam allows for the mounting of 2 SAFER lifters increasing the load handling characteristics without complicating the overall simplicity of the process.

■ BLM-1 handles loads up to 960 kgs and 3000mm while BLM-2 handles loads up to 1920kg and 3000mm in length.

	BLM-1	BLM-2
A (mm)	1680	1900
B (mm)	300	415
C (mm)	130	160
D (mm)	15	20
Weight (kg)	37	75

	BLM-1	BLM-1	BLM-2	BLM-2
In Combination with:	2 x SAFER-300	2 x SAFER-600	2 x SAFER-600	2 x SAFER-1000
Plates				
Load (kg)	480	960	960	1920
Max Length (mm)	3000	3000	3000	3000
Max Width (mm)	1500	1500	1500	1500
Rounds				
Load (kg)	240	480	480	960
Max Length (mm)	3000	3000	3000	3000

PRA

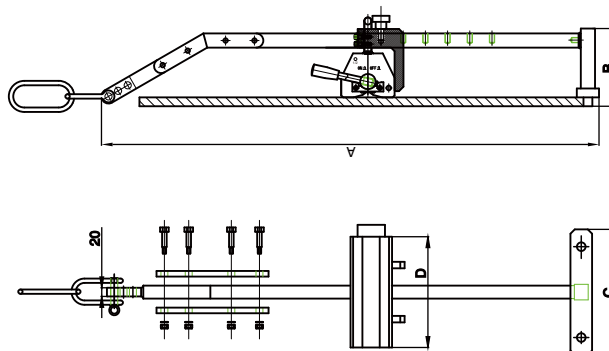

• PRA - SAFER Vertical System

Features:

■ PRA system is designed for the vertical handling of steel blocks. The typical application is loading / unloading a workpiece on a horizontal spindle milling machine.

■ Can be used to flip parts over as needed in a safe manner using simple stalls is possible to fix the workpiece to the magnetic chuck from one side to other one, so as to work both faces.

■ PRA is easily adaptable to workpieces of different sizes, changing the position of locking pins.

■ PRA is available for SAFER 300/600.

Technical characteristics

With PRA	PRA 300	PRA 600
A (mm)	1121	1121
B (mm)	175	175
C (mm)	290	290
D (mm)	152	256
Weight (kg)	31	42

With PRA	PRA 300	PRA 600
Load Max (kg)	250	500
Max length plate (mm)	800	1000
Min length plate (mm)	300	300
Min thickness plate (mm)	4	6
Max width plate (mm)	550	700



CUA / CUD / CUT



• One channel control unit

Use:
Electro-permanent magnetics modules for milling / grinding

- Features:**
- Multiple input voltage choices
 - Micro computer controls self testing and magnetizing detection
 - Good for both 50 Hz and 60 Hz
 - PLC connection built in
 - Safe and reliable
 - Including 5 meters power cable and 5 meters discharge cable

Model	Length	Width	Height	Net weight	Box
CUA-H	300 (11.81)	200 (7.87)	105 (4.13)	1.6 kg / 3.5 lb	Plastic
CGA-H	300 (11.81)	200 (7.87)	105 (4.13)	1.6 kg / 3.5 lb	Plastic

Voltage	Max. Pole No. / channel	Pole size
220 V	56	50 x 50 mm
400 / 480 V	84	50 x 50 mm

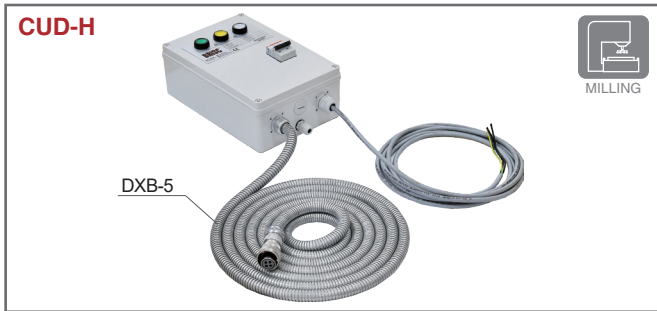

• Two channels control unit

Use:
Electro-permanent magnetics modules for milling / grinding

- Features:**
- Multiple input voltage choices
 - Micro computer controls self testing and magnetizing detection
 - Good for both 50 Hz and 60 Hz
 - PLC connection built in
 - Safe and reliable
 - Including 5 meters power cable and 5 meters discharge cable

Model	Length	Width	Height	Net weight	Box
CUD-H	300 (11.81)	200 (7.87)	105 (4.13)	2.0 kg / 4.4 lb	Plastic
CGD-H	300 (11.81)	200 (7.87)	105 (4.13)	2.0 kg / 4.4 lb	Plastic

Voltage	Max. Pole No. / channel	Pole size
220 V	56	50 x 50 mm
400 / 480 V	84	50 x 50 mm



• Two channels control unit

Use:
Electro-permanent magnetics modules for milling

- Features:**
- Multiple input voltage choices
 - Micro computer controls self testing and magnetizing detection
 - Good for both 50 Hz and 60 Hz
 - PLC connection built in
 - Safe and reliable
 - Including 5 meters power cable and 5 meters discharge cable
 - With channel selection function

Model	Length	Width	Height	Net weight	Box
CUT-A	325 (12.80)	170 (6.69)	90 (3.54)	3.4 kg / 7.5 lb	Metal

Voltage	Max. Pole No. / channel	Pole size
220 V	56	50 x 50 mm
400 / 480 V	84	50 x 50 mm



● One channel control unit

Use:
Electro-permanent magnetics modules for grinding

- Features:**
- Multiple input voltage choices
 - Micro computer controls self testing and magnetizing detection
 - Good for both 50 Hz and 60 Hz
 - PLC connection built in
 - Safe and reliable
 - Strength adjustable

Model	Length	Width	Height	Net weight	Applicatin
CGA-DT	300 (11.81)	200 (7.87)	105 (4.13)	1.6 kg / 3.5 lb	external
CGA-M	210 (8.27)	110 (4.33)	100 (3.94)	1 kg / 2.2 lb	internal

Voltage	Max. current per channel	Max. Pole No. per channel	Pole size
220 V	50 A	56	50 x 50 mm
400 / 480 V	50 A	84	50 x 50 mm



● Two channels control unit

Use:
Electro-permanent magnetics modules for grinding

- Features:**
- Multiple input voltage choices
 - Micro computer controls self testing and magnetizing detection
 - Good for both 50 Hz and 60 Hz
 - PLC connection built in
 - Safe and reliable
 - Strength adjustable

Model	Length	Width	Height	Net weight	Applicatin
CGD-DT	300 (11.81)	200 (7.87)	105 (4.13)	2.0 kg / 4.4 lb	external
CGD-M	260 (8.27)	110 (4.33)	100 (3.94)	1 kg / 2.2 lb	internal

Voltage	Max. current per channel	Max. Pole No. per channel	Pole size
220 V	50 A	56	50 x 50 mm
400 / 480 V	50 A	84	50 x 50 mm



● Eight channels junction box

Use:
Fast connections between chucks and control unit

- Features:**
- Die cast aluminum box
 - IP65 water resistant
 - HARTING connector for quick connection

Model	Length	Width	Height	Net weight
JB-22	280 (11.02)	230 (9.06)	110 (4.33)	4.5 kg / 9.9 lbs

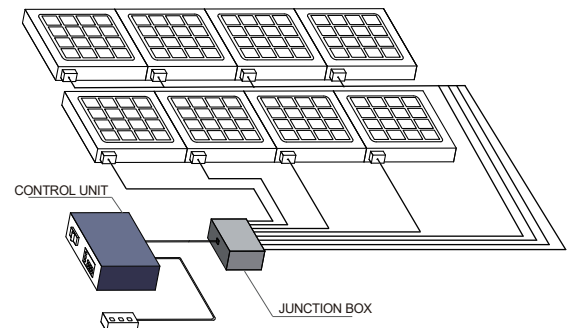

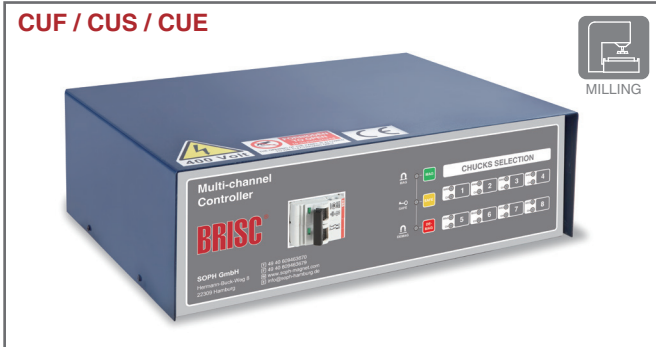

• Multi-channels control unit

Use:
Selectable channel multi-channel controller for electro-permanent magnets

- Features:**
- Multiple input voltage choices
 - Micro computer controls self testing and magnetizing detection
 - Good for both 50 Hz and 60 Hz
 - PLC connection built in
 - Safe and reliable
 - With channel selection function
 - Can be used jointly

Model	Length	Width	Height	Net weight	Channels
CUF	383 (15.08)	289 (11.38)	129 (5.08)	8 kg / 17.6 lb	4
CUS	383 (15.08)	289 (11.38)	129 (5.08)	8 kg / 17.6 lb	6
CUE	383 (15.08)	289 (11.38)	129 (5.08)	8 kg / 17.6 lb	8
CGF	383 (15.08)	289 (11.38)	129 (5.08)	8 kg / 17.6 lb	4
CGS	383 (15.08)	289 (11.38)	129 (5.08)	8 kg / 17.6 lb	6
CGE	383 (15.08)	289 (11.38)	129 (5.08)	8 kg / 17.6 lb	8

Voltage	Max. Pole No. / channel	Pole size
220 V	56	50 x 50 mm
400 / 480 V	84	50 x 50 mm

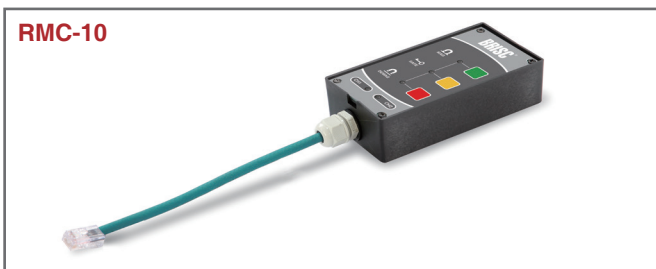
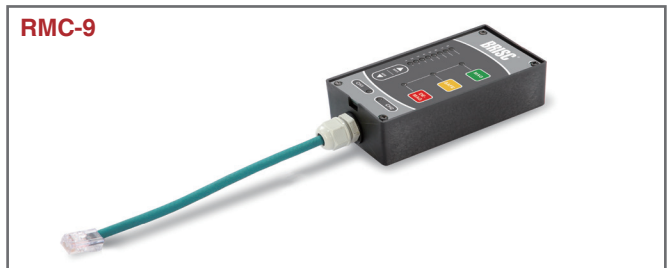
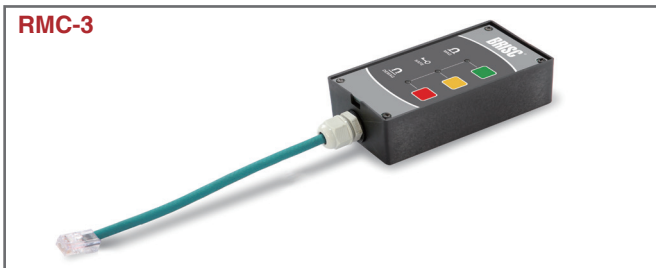
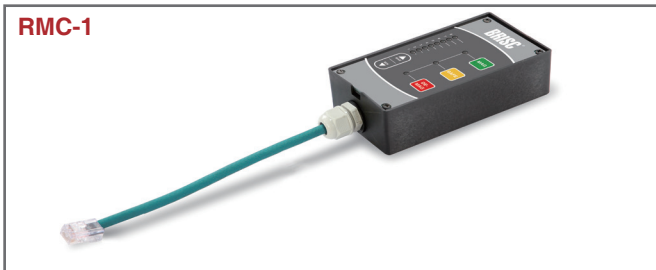

• Remote control

Use:
For wire remote control

- Features:**
- Small and compact
 - With magnetic plate on the rear for ease of attachment

Model	Length	Width	Height	Strength adjustable	Channel Selection
RMC-1	136 (5.35)	66 (2.60)	41 (1.61)	Yes	No
RMC-2	136 (5.35)	66 (2.60)	55 (2.17)	Yes	No
RMC-3	136 (5.35)	66 (2.60)	41 (1.61)	No	No
RMC-9	136 (5.35)	66 (2.60)	41 (1.61)	Yes	Yes
RMC-10	136 (5.35)	66 (2.60)	41 (1.61)	No	Yes
RMC-14	136 (5.35)	66 (2.68)	55 (2.17)	Yes	No



● Control unit for electromagnetic chucks

Use:
Use with any electromagnetic chucks with input of 130 VAC and output 115 VDC and capacity of up to 500 watts

- Features:**
- External use design
 - Push button control allows easy selection of full, residual, variable, and release positions
 - Automatic release cycle assures workpiece release, while freeing machine operators from manual demagnetizing operations
 - Current sense and E-stop interlock with machine
 - Up to 16 pole reversal programs

Model	Length	Width	Height	Strength adjustable
CEB	280 (11.02)	230 (9.06)	110 (4.33)	Yes



● Control unit for electromagnetic chucks

Use:
Use with any electromagnetic chucks with input of 130 VAC and output 115 VDC and capacity of up to 500 watts

- Features:**
- Internal use design
 - Touchpad control allows easy selection of full, residual, variable, and release positions
 - Automatic release cycle assures workpiece release, while freeing machine operators from manual demagnetizing operations
 - Current sense and E-stop interlock with machine
 - Up to 3 pole reversal programs
 - Can be used jointly

Model	Length	Width	Height	Strength adjustable
CED	172 (6.77)	55 (2.17)	120 (4.72)	Yes



● Control unit for electro-permanent magnetic chucks

Use:
Electro-permanent magnetics modules for grinding and milling

- Features:**
- Universal use for all magnet types
 - Multiple input voltage choices
 - Micro computer controls self testing and magnetizing detection
 - Good for both 50 Hz and 60 Hz
 - PLC connection built in
 - Safe and reliable
 - Multi-demag pattern for different material

Model	Length	Width	Height	Net weight
CUK-A	250 (9.8)	195 (7.7)	106 (4.2)	3.2 kg / 7.1 lb



● Control unit for electro magnetic chucks

Use:
Use with any electromagnetic chucks

- Features:**
- Internal use design
 - Micro computer controls self testing and magnetizing detection
 - PLC connection built in
 - Safe and reliable

Model	Length	Width	Height	Net weight
ECC-10/20/30/50	250 (9.8)	195 (7.7)	106 (4.2)	3.2 kg / 7.1 lb

Model	Input Voltage	Output Voltage	Current Capacity
ECC-10	AC 220 V /Single Phase	DC 0-110 V	10 A
ECC-20	AC 220 V /Single Phase	DC 0-110 V	20 A
ECC-30	AC 420 V /Three Phase	DC 0-110 V	30 A
ECC-50	AC 420 V /Three Phase	DC 0-110 V	50 A



BRISC[®]

© 1998 - 2022, SOPH GmbH, Hamburg, Germany

Copyright

All text, drawings, photos and product illustrations are subject to copyright and are the property of SOPH GmbH

Technical Changes

The data and illustrations in this catalogue are not binding and only provide an approximate description. We reserve the right to make changes to the product delivered compared with the data and illustrations in this catalogue, e.g. in respect of technical data, design, fittings, material and external appearance.

SOPH GmbH

Hermann-Buck-Weg 8, 22309 Hamburg

Tel: +49-40-609463670 Fax: +49-40-609463679

info@soph-gmbh.com

SOPH Inc

195 South Alloy Dr. Fenton MI 48430

Tel: +1-810-750-1120 Fax: +1-810-750-1141

info@soph-inc.com

SOPH Ltd

Building 3, No.6 Xin Zhong Rd, Haining 314400

Tel: 86-0573-89262865 Fax: 86-0573-89262863

info@soph-ltd.com

www.soph-magnet.com